

MAXIMUM SECURITY

3/8" x 1/8" Openings

STANDARD FEATURES

- **FACE FLANGE:** Beveled Edge - 12-gauge C.R.S.
- **OPENINGS:** with 3/8" x 1/8" Horizontal Louvers and Vertical Mullions of 12-gauge C.R.S.
- **AIR PASSAGEWAYS:** Patented "S" style eliminates 'looping' of materials around/or through louvers
- **NECK:** Rigid with 1-7/16" exposed face depth made of multiple piece 12-gauge construction
- **INSTALLS:** Coupling nut with threaded rods attaches to rear of face flange and duct connector
- **DUCT COLLAR:** Mating 14 gauge galvanized mounting frame with nuts (integral face/duct connection)

FINISH

- Multi-stage surface preparation and powder coat finish (5-7 mil. thickness) beige or white, must specify .
- **OPTIONAL:** Custom powder coat colors. Rust inhibiting prime coat. Consult factory for other finishes.

OPTIONAL FEATURES

- **MATERIAL GAUGES:** other material gauges available
- **MATERIAL:** stainless steel
- **FACE MOUNTED:** connections available
- **PATENTED PLENUM BOX:** for retrofit connection
- **SLEEVE AND LOCKING ANGLES**
- **OPPOSED BLADE DAMPERS:** Rear operated
- **ANCHOR STUDS:** Nelson type for precast/brick wall applications
- **TAMPERPROOF SCREWS:** Stainless steel screws (see inside back cover, page i) will be furnished based upon the product and type of installation (see pages A-14 and A-15)

CONSTRUCTION

The grille is made of 12-gauge steel (stainless steel if used in humid areas) with the outer perimeter stamped to raise the grill face 5/16" from the wall or ceiling. The edge of the grill is manufactured with a beveled slope. The portion of the edge of the grille that will contact the wall or ceiling upon installation is machined to a flatness of $\pm 0.003"$. No open or unfinished edges exist. The horizontal louvers are attached to a unweld frame and 'locked in' to prevent movement or removal. The vertical mullions are correspondingly 'locked in' place creating a penetration proof neck and throat of 1-7/16" depth. Coupling nuts are attached to the back of the face flange for use with threaded rods. A mating duct collar with nuts receive the threaded rod and are tightened accordingly.

INSTALLATION

SV3 is installed into the wall (or ceiling) with the threaded rods attached. A mating duct collar with nuts receives the rod and is then tightened to insure a secure fit on both sides of the wall. Optional attachment mechanisms are available for both new and retrofit applications. Optional sleeve, locking angle and opposed blade dampers may be supplied, if required. See pages A-14 and A-15 for Installation Overview.

TOP SECTION

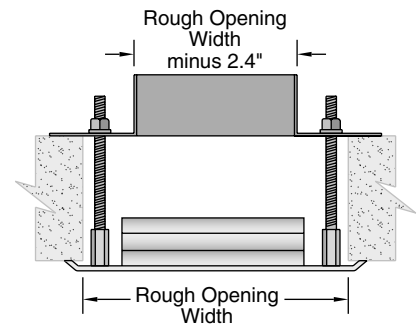

FRONT SECTION

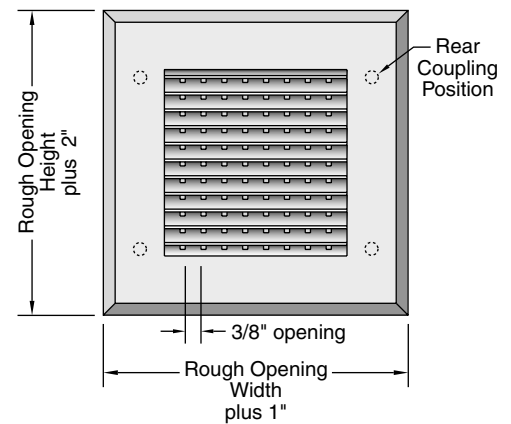

SIDE SECTION

