

INTERNAL RETROFIT KITS

1. Internal retrofit kits are installed without disturbing upstream or downstream ducts and are appealing for owners of occupied buildings. Conversion from constant to variable air volume can be accomplished in as little as 60 minutes per terminal. The work is normally done through a bottom access door, a typical feature included with many vintage air terminals.
2. Internal retrofit projects should include an initial investigation of the air terminals to be modified to verify accessibility, clearances, and model number / design configuration. Anemostat has a significant database of drawings of competitor's air terminals and typically, the retrofit kit fits into the unit as is intended.
3. Anemostat service personnel are available to assist with initial air terminal retrofit assessments as well as an installation demonstration and subsequent training.

TABLE 71: INTERNAL RETROFIT CONTROL SEQUENCES

Existing Air Terminal			Retrofit Sequence #
Type	# of Damper Actuators	Sequence	
Dual Duct	1 – Crosslinked	C.V. Mixing	ID1
Dual Duct	2	C.V. Mixing	ID2
Single Duct w/ Reheat	None	Constant Volume	IS1
Single Duct	1	VAV (Max to 0)	IS2

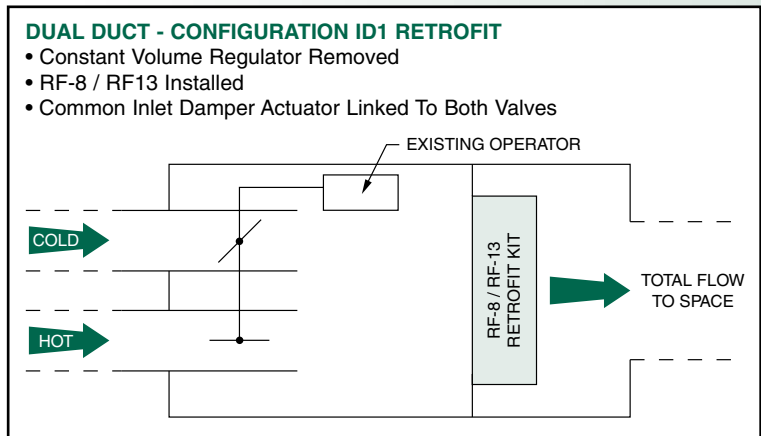

Figure 11

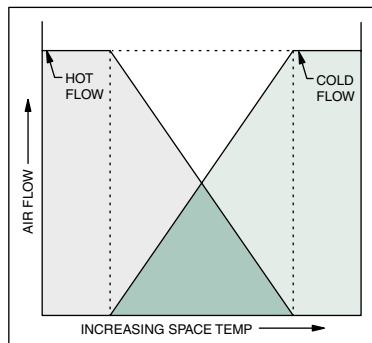

Diagram 11: Typical Flow Diagram For Existing Constant Volume Mixing Terminals. Configurations ID1 & ID2

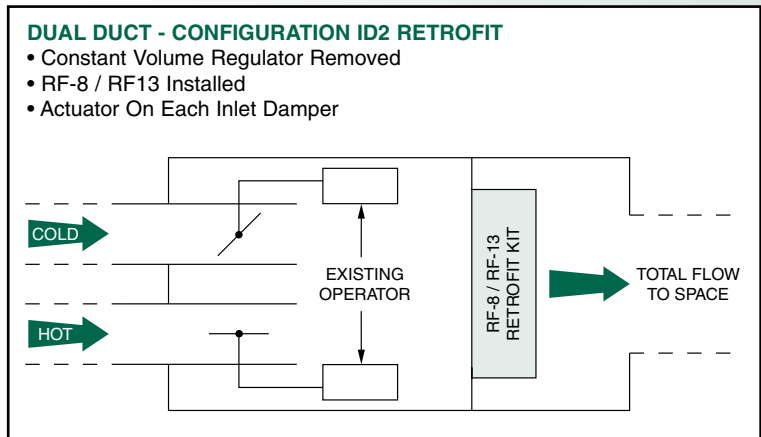

Figure 12

SEQUENCE ID1A, ID2A

No Mixing

- Replace internal regulator(s) with an RF-8 / RF-13 kit. Use existing actuator(s).
- VAV pressure independent cold & hot air flows
- Max Heating and Cooling flow rates are the same
- Existing actuator(s)-dampers change over from cold duct to hot duct flow

SEQUENCE ID1B, ID2B

VAV Cooling with Mixing at Minimum

- Replace internal regulator(s) with an RF-8 / RF-13 kit. Use existing actuator(s)
- VAV pressure independent cold & hot air flows
- Existing actuator(s) are sequenced to modulate dampers at minimum mixing setpoint

SEQUENCE ID1C, ID2C

VAV Cooling with Dual Maximum

- Replace internal regulator(s) with an RF-8 / RF-13 kit. Use existing actuator(s)
- VAV pressure independent cold & hot air flows
- Max Heating and Cooling flow rates are the same
- Existing actuator(s) are sequenced to modulate dampers at minimum mixing setpoint

SEQUENCE ID1A, ID2A (0 MIN)

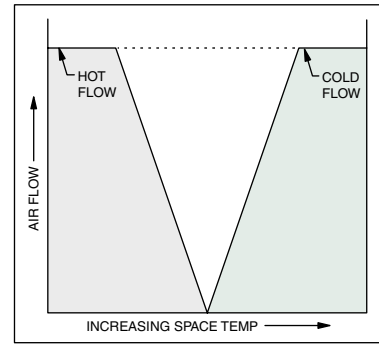

SEQUENCE ID1A, ID2A (MIN > 0)

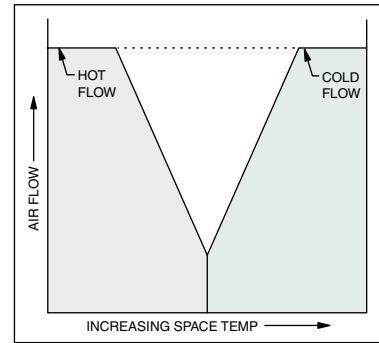

SEQUENCE ID1B, ID2B

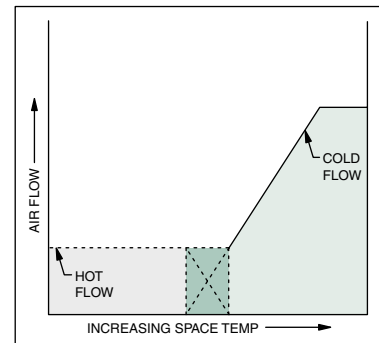

SEQUENCE ID1C, ID2C

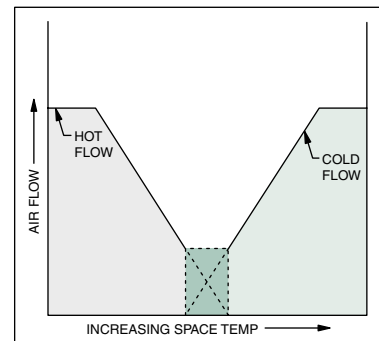

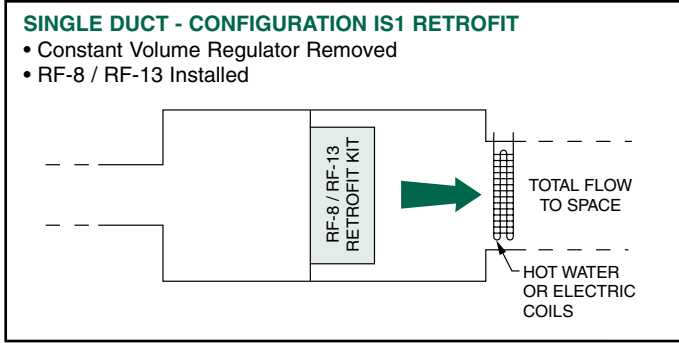
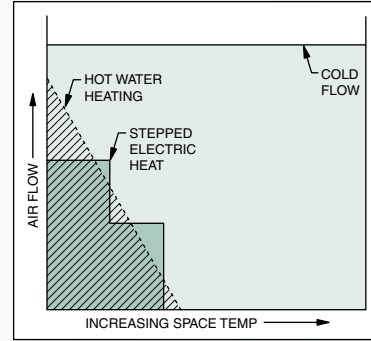

Figure 13



SEQUENCE IS1A

Max-Min VAV

- Replace internal regulator(s) with an RF-8 / RF-13 kit.
- VAV pressure independent airflow with minimum flow for reheat.

SEQUENCE IS1A

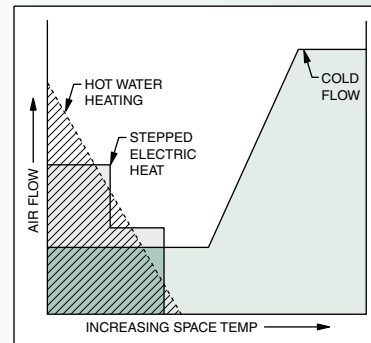

SEQUENCE IS1B

Dual Maximum VAV w / hot water heat

- Replace internal regulator(s) with an RF-8 / RF-13 kit.
- VAV pressure independent airflow with maximum flow for reheat.

SEQUENCE IS1B

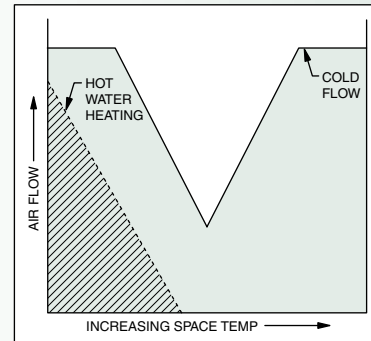

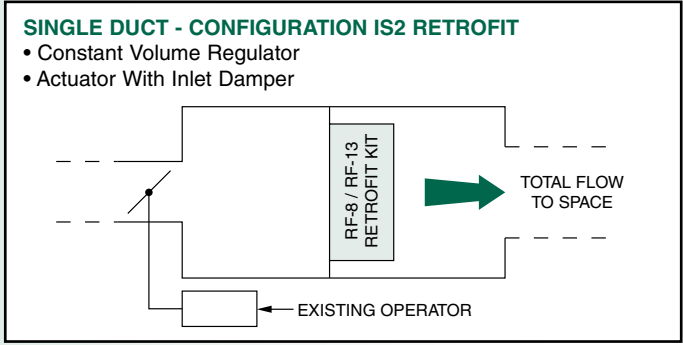

Figure 14

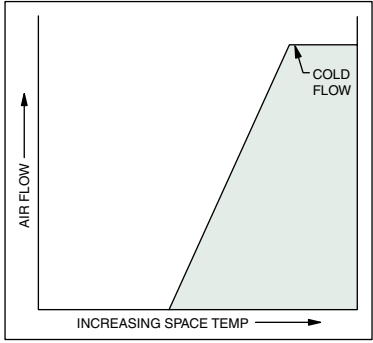

Diagram 12: Typical flow diagram for existing single duct terminal without reheat.

SEQUENCE IS2A

Max-Min VAV

- Replace internal regulator(s) with an RF-8 / RF-13 kit.
- Disable existing actuator – fix existing damper wide open.
- VAV pressure independent airflow

SEQUENCE IS2A

