

**APPLICATION**

- Series type, fan assisted air terminal with integral electric heating coil
- Provide electric resistance heating to perimeter spaces during occupied periods and night cycling temperature control with central fan systems shut down

**FEATURES**

Same as Model QSTS plus:

- Integral electric heating coil with nickel-chrome resistance wire
- Primary, auto reset thermal cutout
- Fan interlock relay for proof of air flow
- 24vac Class II transformer (unfused) as required for 24vac control systems
- PE switches for pneumatic control systems
- Magnetic de-energizing contactor per step
- Accepts flanged discharge duct connection
- Left hand control and heater cabinet position are standard



**OPTIONS & ACCESSORIES**

Same as Model QSTS plus:

- Door interlocking disconnect switch, non-fused
- Air flow switch in lieu of fan interlock relay
- Power fusing (fuses & fuse blocks)
- Manual reset secondary thermal cutout
- SSR modulating controller

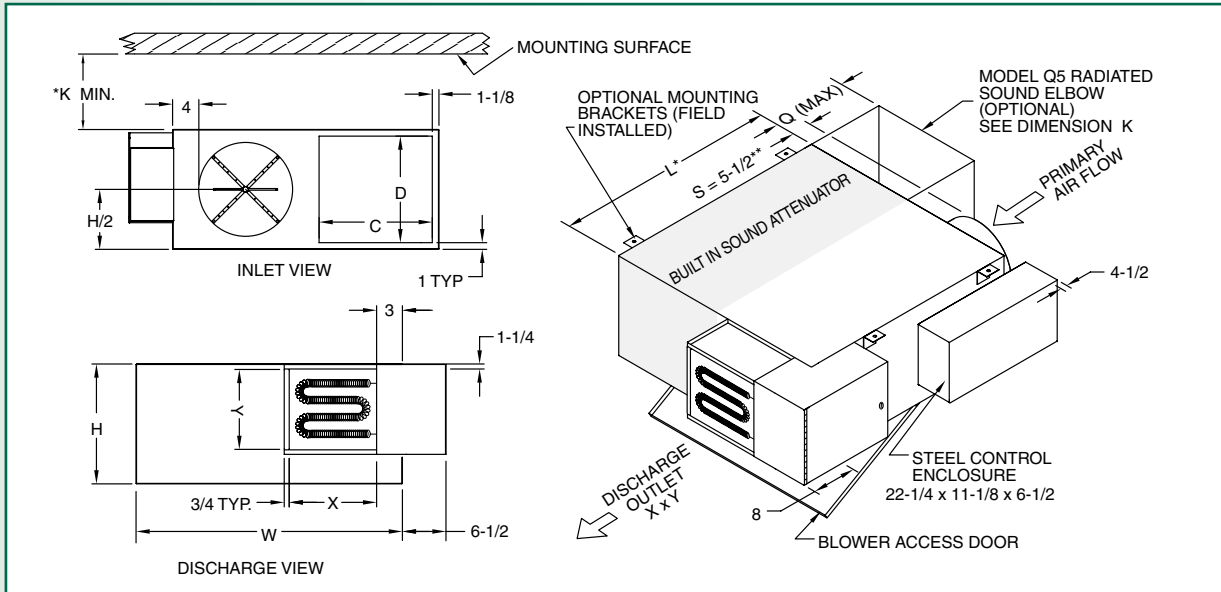

Model Number QSTE	Motor H.P.	Nominal Inlet Diameter	Height H	Width W	Length L	Min. K	Discharge		Induction		Q	Est. Wt. LB
							X	Y	C	D		
1706, 1707, 1708	1/6	6,7,8	18	32	36	6	11-1/2	11	12	16	18	142
2508, 2509, 2510	1/4	8,9,10	18	32	36	6	11-1/2	11	12	16	18	146
5010, 5012, 5014	1/2	10,12,14	18	40	40	6	14	12	17	16	18	162
7512, 7514	3/4	12,14	20	48	48	8	19	16	21	18	20	217
1012, 1014, 1016	1	12,14,16	20	48	48	8	19	16	21	18	20	224