



## AIR FLOW SOLUTIONS

Installation, Operation, & Maintenance

### **MODEL QST**

Quiet, Series (Continuous) Flow  
VAV Terminal Unit

### **MODEL QPT**

Quiet, Parallel (Intermittent) Flow  
VAV Terminal Unit

### **MODEL EST**

Energy Smart Series (Continuous) Flow  
VAV Terminal Unit

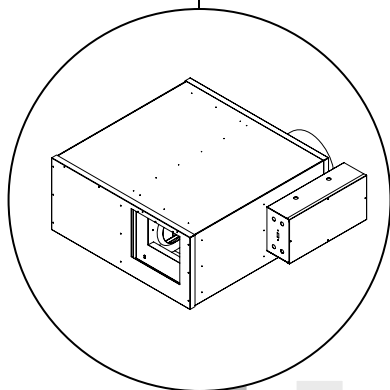

## Table of Contents

Model QST Number Description .....	3
Model EST Number Description .....	4
Model QPT Number Description .....	5
Unit Labeling .....	6
Receiving and Inspection Instructions .....	7
Warnings .....	7
Terminal Installation .....	8
Clearance Requirements .....	8
Duct Connections and Insulation .....	8
Hot Water Connections .....	9
Electrical Connections .....	9
QSTS Standard Unit Dimensions and Weights .....	10
QSTE Electric Heat Unit Dimensions and Weights .....	11
QSTW Hot Water Unit Dimensions and Weights .....	12
ESTS Standard Unit Dimensions and Weights .....	13
ESTE Electric Heat Unit Dimensions and Weights .....	14
ESTW Hot Water Unit Dimensions and Weights .....	15
QPTS Standard Unit Dimensions and Weights .....	16
QPTE Electric Heat Unit Dimensions and Weights .....	17
QPTW Hot Water Unit Dimensions and Weights .....	18
General Controller Information .....	19
Pneumatic Connections .....	19
Primary Airflow Adjustment .....	19
Airflow Sensor $\Delta P$ Versus Air Flow Chart – Pneumatic Controls .....	20
Electronic Analog Connection .....	20
Factory Mounted DDC Controls .....	20
Primary Airflow Adjustment (Electric Analog Controls) .....	21
Altitude Correction Factors .....	22
Fan Discharge Airflow Adjustments .....	23
QST Unit Fan and Primary Flow Range Selection .....	24
EST Unit Fan and Primary Flow Range Selection .....	24
QPT Unit Fan and Primary Flow Range Selection .....	25
Service and Maintenance .....	26
Troubleshooting .....	27-33
Standard Replacement Parts List .....	34

# Model QST Number Description

Standard Digits	1-3	4	5,6	7,8	9	10	11	12-15	16	17-20	21-24	25	26	27	28-30	31-32	33-34	35-+
Description	Model Num	Heat	HP	Inlet	Casing	Insul	Cntrl Type	Cntrl Pkg	LH	Min CFM	Max CFM	Heat Config	Fan VAC	Coil VAC	Elec KW	Opt	Opt	Opt
Example	QST	W	25	10	B	1	A	5001	L	0100	1450	E	1	G	12	C1	C4	F1

### Digit 1, 2, 3 - Model

QST Series flow fan powered terminal

### Digit 4 - Heat options

S Standard  
 W Hot water coil  
 E Electric heat

### Digit 5, 6, 7, 8 - Fan Horsepower and Primary inlet size

1706 1/6 hp 6" inlet  
 1707 1/6 hp 7" inlet  
 1708 1/6 hp 8" inlet  
 2508 1/4 hp 8" inlet  
 2509 1/4 hp 9" inlet  
 2510 1/4 hp 10" inlet  
 5010 1/2 hp 10" inlet  
 5012 1/2 hp 12" inlet  
 5014 1/2 hp 14" inlet  
 7512 3/4 hp 12" inlet  
 7514 3/4 hp 14" inlet  
 1012 1 hp 12" inlet  
 1014 1 hp 14" inlet  
 1016 1 hp 16" inlet

### Digit 9 - Casing Construction

B single wall 20ga. Steel (standard)  
 E double wall 22ga. Steel (1/2" glass fiber insulation)  
 F low temp casing (1" matte faced glass fiber insulation)

### Digit 10 - Insulation and Treatment

0 None  
 1 1/2" matte-faced glass fiber insulation (double wall only)  
 2 1" matte-faced glass fiber insulation (standard) (also req'd for low temp casing)  
 3 1/2" foil-faced glass fiber (tape over all insulation edges)  
 4 1" foil-faced glass fiber (tape covers insulation edges)  
 5 3/8" closed cell insulation (fiber free)

### Digit 11 - Control Type

0 None  
 P Pneumatic  
 A Electronic Analog  
 F Supplied by others – factory mounted

### Digits 12, 13, 14, 15 - Control Package

0000 None (field supplied by others)  
 XXXX Refer to pages 365 and 366

### Digit 16 - Control location (determined by facing inlet)

L left hand

### Digits 17, 18, 19, 20 - Primary air minimum airflow

0000 None specified  
 XXXX Specify minimum airflow setting in CFM  
 Refer to pages 365 and 366 for allowable range

### Digits 21, 22, 23, 24 - Primary air maximum airflow

0000 None specified  
 XXXX Specify maximum primary airflow setting in CFM. Refer to pages 365 and 366

### Digit 25 - Heating coil and connection location (determine by facing inlet)

0 None  
 A One-row hot water coil - right hand  
 B One-row hot water coil - left hand  
 C Two-row hot water coil - right hand  
 D Two-row hot water coil - left hand  
 K Electric heat - connections same side as digit 16

### Digit 26 - Fan Motor Voltage

1 115V/ 1 Ph./ 60 Hz.  
 2 277V/ 1 Ph./ 60 Hz.

**Note:** Standard motor is 3 speed multi-tap PSC

### Digit 27 - Electric Coil Voltage and Steps

0 None  
 A 208V/ 1 Ph/ 60Hz. 1 step  
 B 208V/ 1 Ph/ 60Hz. 2 step  
 C 208V/ 1 Ph/ 60Hz. 3 step  
 D 240V/ 1 Ph/ 60Hz. 1 step  
 E 240V/ 1 Ph/ 60Hz. 2 step  
 F 240V/ 1 Ph/ 60Hz. 3 step  
 G 277V/ 1 Ph/ 60Hz. 1 step  
 H 277V/ 1 Ph/ 60Hz. 2 step  
 J 277V/ 1 Ph/ 60Hz. 3 step  
 K 208V/ 3 Ph/ 60Hz. 1 step  
 L 208V/ 3 Ph/ 60Hz. 2 step  
 M 208V/ 3 Ph/ 60Hz. 3 step  
 N 480V/ 3 Ph/ 60Hz. 1 step  
 P 480V/ 3 Ph/ 60Hz. 2 step  
 R 480V/ 3 Ph/ 60Hz. 3 step

Must be 4 wire WYE configuration

**Note:** 3 steps not available with night setback control packages

### Digits 28, 29, 30 - Electric coil KW

000 None  
 XXX Refer to notes on pages 369 and 370 for allowable range

### Digit 31 and over - Options and Accessories

C1 Unit mounting brackets  
 C2 Manual damper locking quadrant (shipped loose)  
 C4 Hinged front panel control enclosure  
 C5 Discharge collar ("S" units only)  
 D3 Line voltage SPST disconnect switch (120V, 277V)  
 D5 Line voltage power-fusing (fuse and block for 120V, 277V)  
 D7 Three speed motor switch (terminal selector block standard)  
 D8 Fan Relay, 24 VAC Coil, SPST / N.O. (for DDC controls by others)  
 D9 24 VAC Electric Actuator  
 DA 24 VAC Transformer, 40 VA  
 E1 Non-fused interlocking disconnect switch for Electric heat  
 E2 Electric heat Mercury de-energizing contactors  
 E3 Electric heat power fusing (fuses and fuse blocks)  
 E4 Electric heat manual reset secondary thermal cutout  
 E6 AirFlow proving switch  
 F1 One inch throwaway filters

# Model EST Number Description

Standard Digits	1-3	4	5,6	7,8	9	10	11	12-15	16	17-20	21-24	25-28	29	30	31	32-34	35-36	37-38	39-+
Description	Model Num	Heat	HP	Inlet	Casing	Insul	Cntrl Type	Cntrl Pkg	LH	Min CFM	Max CFM	Fan CFM	Heat Config	Fan VAC	Coil VAC	Elec KW	Opt	Opt	Opt
Example	EST	E	10	14	B	1	A	5001	L	900	2000	2000	K	2	N	08.0	E1	F1	K2

### Digit 1, 2, 3 - Model

EST Series flow fan powered terminal with ECM motor

### Digit 4 - Heat options

S Standard  
 W Hot water coil  
 E Electric heat

### Digit 5, 6, 7, 8 - Fan Horsepower and Primary inlet size

3306	1/3 hp 6" inlet	7507	3/4 hp 7" inlet
3307	1/3 hp 7" inlet	7508	3/4 hp 8" inlet
3308	1/3 hp 8" inlet	7509	3/4 hp 9" inlet
3309	1/3 hp 9" inlet	7510	3/4 hp 10" inlet
3310	1/3 hp 10" inlet	7512	3/4 hp 12" inlet
5006	1/2 hp 6" inlet	7514	3/4 hp 14" inlet
5007	1/2 hp 7" inlet	1009	1 hp 9" inlet
5008	1/2 hp 8" inlet	1010	1 hp 10" inlet
5009	1/2 hp 9" inlet	1012	1 hp 12" inlet
5010	1/2 hp 10" inlet	1014	1 hp 14" inlet
5012	1/2 hp 12" inlet	1016	1 hp 16" inlet
5014	1/2 hp 14" inlet		

### Digit 9 - Casing Construction

B single wall 20ga. Steel (standard)  
 E double wall 22ga. Steel (1/2" glass fiber insulation)  
 F low temp casing (1" matte faced glass fiber insulation)

### Digit 10 - Insulation and Treatment

0 None  
 1 1/2" matte-faced glass fiber insulation (double wall only)  
 2 1" matte-faced glass fiber insulation (standard) (also req'd for low temp casing)  
 3 1/2" foil-faced glass fiber (tape over all insulation edges)  
 4 1" foil-faced glass fiber (tape covers insulation edges)  
 5 3/8" closed cell insulation (fiber free)

### Digit 11 - Control Type

0 None  
 P Pneumatic  
 A Electronic Analog  
 F Supplied by others - factory mounted

### Digits 12, 13, 14, 15 - Control Package

0000 None (field supplied by others)  
 XXXX Refer to available control packages

### Digit 16 - Control location (determined by facing inlet)

L left hand

### Digits 17, 18, 19, 20 - Primary air minimum airflow

0000 None specified  
 XXXX Specify minimum airflow setting in CFM

### Digits 21, 22, 23, 24 - Primary air maximum airflow

0000 None specified  
 XXXX Specify maximum primary airflow setting in CFM.

### Digits 25, 26, 27, 28 - Fan CFM

0000 None specified  
 XXXX Specify fan CFM.

### Digit 29 - Heating coil and connection location (determine by facing inlet)

0 None  
 A One-row hot water coil - right hand  
 B One-row hot water coil - left hand  
 C Two-row hot water coil - right hand  
 D Two-row hot water coil - left hand  
 K Electric heat - connections same side as digit 16

### Digit 30 - Fan Motor Voltage

1 115V/ 1 Ph./ 60 Hz.  
 2 277V/ 1 Ph./ 60 Hz.  
 3 240V/ 1 Ph./ 60 Hz.

### Digit 31 - Electric Coil Voltage and Steps

0 None  
 A 208V/ 1 Ph/ 60Hz. 1 step  
 B 208V/ 1 Ph/ 60Hz. 2 step  
 C 208V/ 1 Ph/ 60Hz. 3 step  
 D 240V/ 1 Ph/ 60Hz. 1 step  
 E 240V/ 1 Ph/ 60Hz. 2 step  
 F 240V/ 1 Ph/ 60Hz. 3 step  
 G 277V/ 1 Ph/ 60Hz. 1 step  
 H 277V/ 1 Ph/ 60Hz. 2 step  
 J 277V/ 1 Ph/ 60Hz. 3 step  
 K 208V/ 3 Ph/ 60Hz. 1 step  
 L 208V/ 3 Ph/ 60Hz. 2 step  
 M 208V/ 3 Ph/ 60Hz. 3 step  
 N 480V/ 3 Ph/ 60Hz. 1 step  
 P 480V/ 3 Ph/ 60Hz. 2 step  
 R 480V/ 3 Ph/ 60Hz. 3 step

Must be 4 wire WYE configuration

**Note:** 3 steps not available with night setback control packages

### Digits 32, 33, 34 - Electric coil KW

000 None  
 XXX Refer to notes for allowable range

### Digit 35 and over - Options and Accessories

C1 Unit mounting brackets  
 C2 Manual damper locking quadrant (shipped loose)  
 C4 Hinged front panel control enclosure  
 C5 Discharge collar ("S" units only)  
 D3 Line voltage SPST disconnect switch (120V, 277V)  
 D5 Line voltage power-fusing (fuse and block for 120V, 277V) (terminal selector block standard)  
 D8 Fan Relay, 24 VAC Coil, SPST / N.O. (for DDC controls by others)  
 D9 24 VAC Electric Actuator  
 DA 24 VAC Transformer, 40 VA  
 E1 Non-fused interlocking disconnect switch for Electric heat  
 E2 Electric heat Mercury de-energizing contactors  
 E3 Electric heat power fusing (fuses and fuse blocks)  
 E4 Electric heat manual reset secondary thermal cutout  
 E6 AirFlow proving switch  
 F1 One inch throwaway filters  
 K1 0-10 VDC input signal from DDC controller  
 K2 Manual fan adjust via screwdriver w/on-off position  
 K3 4-20 mA input signal from DDC controller  
 K4 Manual fan adjust via 2 rotary switches  
 K5 Manual selection 1 of 4 pre-programmed fan flow rates  
 K6 Factory set fan CFM

# Model QPT Number Description

Standard Digits	1-3	4	5	6,7	8,9	10	11	12	13-16	17	18-21	22-25	26	27	28	29-31	32-33	34-35	36+
Description	Model Num	Heat	Cabinet Size	HP	Inlet Size	Casing	Insul	Ctrl Type	Ctrl Pkg	LH	Min CFM	Max CFM	Heat Config	Fan VAC	Coil VAC	Elec KW	Opt	Opt	Opt
Example	QPT	W	1	17	06	B	1	A	5001	L	0100	1450	E	1	G	12.0	C1	C4	F1

### Digit 1, 2, 3 - Model

QPT Parallel flow fan powered terminal

### Digit 4 - Heat options

- S Standard
- W Hot water coil
- E Electric heat

### Digit 5, 6, 7, 8, 9 - Cabinet size, Fan HP and Primary inlet size

1 17 06	1/6 hp 6" inlet	2 50 09	1/2 hp 9" inlet
1 17 07	1/6 hp 7" inlet	2 50 10	1/2 hp 10" inlet
1 17 08	1/6 hp 8" inlet	2 50 12	1/2 hp 12" inlet
1 17 09	1/6 hp 9" inlet	3 50 12	1/2 hp 12" inlet
1 25 06	1/4 hp 6" inlet	3 50 14	1/2 hp 14" inlet
1 25 07	1/4 hp 7" inlet	3 50 16	1/2 hp 16" inlet
1 25 08	1/4 hp 8" inlet	3 75 12	3/4 hp 12" inlet
1 25 09	1/4 hp 9" inlet	3 75 14	3/4 hp 14" inlet
2 17 09	1/6 hp 9" inlet	3 75 16	3/4 hp 16" inlet
2 17 10	1/6 hp 10" inlet	3 10 12	1 hp 12" inlet
2 17 12	1/6 hp 12" inlet	3 10 14	1 hp 14" inlet
2 25 09	1/4 hp 9" inlet	3 10 16	1 hp 16" inlet
2 25 10	1/4 hp 10" inlet		
2 25 12	1/4 hp 12" inlet		

### Digit 10 - Casing Construction

- B single wall 20ga. Steel (standard)
- E double wall 22ga. Steel (1/2" glass fiber insulation)

### Digit 11 - Insulation and Treatment

- 0 None
- 1 1/2" matte-faced glass fiber insulation (double wall only)
- 2 1" matte-faced glass fiber insulation (standard)
- 3 1/2" foil-faced glass fiber (tape over all insulation edges)
- 4 1" foil-faced glass fiber (tape covers insulation edges)
- 5 3/8" closed cell insulation (fiber free)

### Digit 12 - Control Type

- 0 None
- P Pneumatic
- A Electronic Analog
- F Supplied by others – factory mounted

### Digits 13, 14, 15, 16 - Control Package

- 0000 None (field supplied by others)
- XXXX Refer to available control packages

### Digit 17 - Control location (determined by facing inlet)

- L left hand

### Digits 18, 19, 20, 21 - Primary air minimum airflow

- 0000 None specified
- XXXX Specify minimum airflow setting in CFM

### Digits 22, 23, 24, 25 - Primary air maximum airflow

- 0000 None specified
- XXXX Specify maximum primary airflow setting in CFM.

### Digit 26 - Heating coil and connection location (determine by facing inlet)

- 0 None
- A One-row hot water coil - right hand
- B One-row hot water coil - left hand
- C Two-row hot water coil - right hand
- D Two-row hot water coil - left hand
- K Electric heat - connections same side as digit 17

### Digit 27 - Fan Motor Voltage

- 1 115V/ 1 Ph./ 60 Hz.
- 2 277V/ 1 Ph./ 60 Hz.

Note: Standard motor is 3 speed multi-tap PSC

### Digit 28 - Electric Coil Voltage and Steps

- 0 None
- A 208V/ 1 Ph/ 60Hz. 1 step
- B 208V/ 1 Ph/ 60Hz. 2 step
- C 208V/ 1 Ph/ 60Hz. 3 step
- D 240V/ 1 Ph/ 60Hz. 1 step
- E 240V/ 1 Ph/ 60Hz. 2 step
- F 240V/ 1 Ph/ 60Hz. 3 step
- G 277V/ 1 Ph/ 60Hz. 1 step
- H 277V/ 1 Ph/ 60Hz. 2 step
- J 277V/ 1 Ph/ 60Hz. 3 step
- K 208V/ 3 Ph/ 60Hz. 1 step
- L 208V/ 3 Ph/ 60Hz. 2 step
- M 208V/ 3 Ph/ 60Hz. 3 step
- N 480V/ 3 Ph/ 60Hz. 1 step
- P 480V/ 3 Ph/ 60Hz. 2 step
- R 480V/ 3 Ph/ 60Hz. 3 step

Must be 4 wire WYE configuration

Note: 3 steps not available with night setback control packages

### Digits 29, 30, 31 - Electric coil KW

- 000 None
- XXX Refer to notes on pages 369 and 370 for allowable range

### Digit 32 and over - Options and Accessories





- C1 Unit mounting brackets
- C2 Manual damper locking quadrant (shipped loose)
- C4 Hinged front panel control enclosure
- C5 Discharge collar ("S" units only)
- D3 Line voltage SPST disconnect switch (120V, 277V)
- D5 Line voltage power-fusing (fuse and block for 120V, 277V) (terminal selector block standard)
- D7 Three speed motor switch (terminal selector block standard)
- D8 Fan Relay, 24 VAC Coil, SPST / N.O. (for DDC controls by others)
- D9 24 VAC Electric Actuator
- DA 24 VAC Transformer, 40 VA
- E1 Non-fused interlocking disconnect switch for Electric heat
- E2 Electric heat Mercury de-energizing contactors
- E3 Electric heat power fusing (fuses and fuse blocks)
- E4 Electric heat manual reset secondary thermal cutout
- E6 AirFlow proving switch
- F1 One inch throwaway filters

## Unit Labeling

Labels are applied to each terminal as follows:

- Unit specific nameplate showing model number, serial number, manufactured date, and information regarding controls and heat provided as appropriate.
- The appropriate airflow calibration chart indicating the airflow at varying airflow sensor signals as shown on pages 16 and 17.
- The appropriate wiring/piping diagram for controls provided by Anemostat, as well as directions for field adjusting the minimum and maximum airflow settings.
- Up arrow indicating the proper orientation of the unit for installation.
- Airflow direction arrow indicating the proper orientation of the duct connections.
- ARI logo indicating the units performance is ARI certified.
- Sheet Metal Workers Union logo indicating unit produced by members of The Sheet Metal Workers Union.

The unit also is shipped with a protective tape over the inlet collar. This tape must be removed prior to connecting the duct work to the inlet collar.

<div style="border: 1px solid black; padding: 5px; text-align: center; margin-bottom: 10px;">  <b>WARNING</b> </div> <p style="text-align: center;"><b>RISK OF ELECTRIC SHOCK CAN CAUSE INJURY OR DEATH DISCONNECT ALL REMOTE POWER SUPPLIES BEFORE SERVICING</b></p> <p style="text-align: center;">Do not block or otherwise cover control cabinet with insulation or other materials</p> <p>CAUTION: MOUNT WITH THE LOWEST MOVING PARTS AT LEAST 8 FEET ABOVE FLOOR OR GRADE LEVEL.</p> <p>SEE INSTALLATION INSTRUCTIONS OR WIRING DIAGRAM FOR SPACING BETWEEN UNITS, TEMPERATURES, AIR VELOCITY, ETC.</p> <p>MODEL/MODÈLE: QST XXXXXXXXXXXXXXXXXXXXXXXXXXXXX SERIAL NO: XXXXXXXXXXXXX TAG/ÉTIQUETTE: XXXXX MFG DATE/DATE DE MFG: XXXXXXXX MFG LOCATION/ENDROIT DE MFG: CARSON, CA</p> <p>MOTOR DATA/DONNÉES DE MOTEUR: XXXXXXXXXXXXXXX COIL DATA/DONNÉES D'ENROULEMENT: XXXXXXXXXXXXXXXXXXXX MCA/CIRCUIT MINIMUM AMPACITY: XXXX MOP/PROTECTION MAXIMUM DE SURINTENSITÉ: XXXX</p>	<div style="border: 1px solid black; padding: 5px; text-align: center; margin-bottom: 10px;">  <b>AVERTISSEMENT</b> </div> <p style="text-align: center;"><b>RISQUE DE CHOCS ELECTRIQUES. PEUT CAUSER DES BLESSURES ET MEME ENTRAINER LA MORT. COUPLER LES SOURCES D'ALIMENTATION A DISTANCE AVANT LE DEPANNAGE.</b></p> <p>ATTENTION. S'ASSURER QUE LES PIECES MOBILES SONT A AU MOINS 2, 4M (8pi) DU PLANCHER OU DU SOL.</p> <p>VOIR LES INSTRUCTIONS D'Installation OU LE DIAGRAMME DE CÂBLAGE POUR ESPACER ENTRE LES UNITÉS, LES TEMPÉRATURES, LA VITESSE D'CAir, ETC...</p> <p>MOTOR IS THERMALLY PROTECTED MAXIMUM OUTLET TEMPERATURE: 200F UNIT DESIGNED TO OPERATE AT NO LESS THAN 0.1" ESP CLEARANCE FROM UNIT, CONNECTED DUCT, AND/OR PLENUM TO COMBUSTIBLE MATERIAL: 0"</p> <p>LE MOTEUR EST THERMIQUEMENT PROTEGE L'CUité A CONÇU POUR FONCTIONNER A AUCUN MOINS DE 0.1"EN PARTICULIER DÉGAGEMENT AVEC L'CUité, LE CONDUIT RELIÉ, ET/OU L'CE SPACE AU MATÉRIEL COMBUSTIBLE: 0"</p>
<div style="display: flex; align-items: center; justify-content: center;">  <div style="margin-left: 10px;"> <p><b>ANEMOSTAT</b><sup>®</sup> A MESTEK COMPANY</p> <p style="font-size: small;">FLORENCE, KY      CARSON, CA 859-847-2299      310-835-7500</p> </div> </div>	<div style="display: flex; align-items: center; justify-content: center;">  <div style="margin-left: 10px;"> <p>XXXXXXX CONFORMS TO/SE CONFORME À UL STD 1995 UL STD 429</p> </div> </div>

**SO# XXXXXX/X TAG:XXXX**

## Receiving and Inspection Instructions

- Check the bill of lading to verify receipt of all listed items (including any loose accessory items). Notify the carrier and the local ANEMOSTAT representative of any shortages or items shipped in error.
- Thoroughly examine all units for transportation damage (dents, punctures, etc). If damage is found, immediately notify and file a claim with the carrier. Note details of any damage on the bill of lading before signing for the shipment.
- Each terminal has a nameplate indicating the model number. When requested, the unit may also be mark with job-specific information (tagging). Locate the nameplate and verify that the correct units with options (controls, heating coils, etc) were received as ordered.
- Store units in a secure, dry location in the original packing, and do not stack any higher than as shipped.

## Warning – Electrical Shock, Burn, and other Hazards

- Heating elements must be disconnected, or water coils allowed to cool prior to servicing. Electric heaters may start automatically, or water valves may open intermittently. It is essential to disconnect all power and control circuits prior to servicing to avoid burning hazards.
- All fastening straps or hangers must mechanically lock the terminal in place and withstand typical vibration and/or disturbances during use.
- Use caution during rigging such that all equipment remains adequately secured until it is affixed and secured in its final location.
- All supports must be designed to meet applicable local codes and ordinances. Before rigging and installation, check equipment weights such to ensure temporary and permanent supports are safely maintained.
- Make certain all power sources are disconnected prior to installation or servicing this equipment. Make certain if there are multiple power connections, that all are securely disconnected to avoid electrocution or shock injuries.
- Disconnect control circuits or pneumatic control systems to avoid injury when working on dampers or actuators, which may respond automatically to a remote control source.
- Guard against flame hazards when soldering or brazing water coil connections to avoid personal injury or property damage. Prior to using any open flame, keep a fire extinguisher nearby.
- All insulated units (except closed-cell) contain fiberglass wool. Disturbing the insulation could expose the installer to airborne particles of glass wool fibers and ceramic fibers. Certain jurisdictions feel that exposure to these fibers through inhalation can cause cancer. Glass wool fibers may also cause respiratory, skin or eye irritation.

## Terminal Installation

To ensure proper operation of the Fan Terminal, the following installation procedures must be implemented.

1. UL1995 dictates that the unit must be installed at least eight feet above floor level.
2. Install terminal to allow for straight upstream duct connection to the inlet for optimum flow uniformity, if possible.
3. Extreme care must be used when lifting the unit. **Do not use the air flow measuring tubes for lifting the unit! This could result in damage to the unit and incorrect flow measurements.**
4. The unit must be installed horizontally (the labels will be easily read). With reference to the primary air supply inlet, the fan and primary control enclosure will be on the left side. The motor access door will be on the bottom, where 7 inches of vertical clearance are required to remove the door. The unit may be suspended by four 5/16 hanger rods that are secured through 3/8 diameter hole in the four (optional) hanger brackets. Optional mounting brackets are field installed and should be located as indicated in drawings on page 9 thru 14.
5. Care must be taken so as not to crimp the inlet or discharge duct connections.
6. Proper clearance at the bottom is required for removal and service of the fan terminal components. (see note 4 above) Refer to the following dimensions for each unit size and type to verify adequate spacings.
7. Make certain not to obstruct service access to any electrical enclosures or access panels for access to the interior of the unit.

## Clearance Requirements

- Line voltage and low voltage electrical enclosures must have adequate (minimum 36") clearances to meet requirements of NFPA 70 (NEC). Note that additional clearance requirements may be required by local codes or building construction specifications.
- The motor access door will be on the bottom, where 7 inches of vertical clearance are required to remove the door.
- Unit should hang freely, and not make contact with any structure above.

## Duct Connections and Insulation

The terminal should be installed in a location that offers straight duct upstream of the unit, for best performance.

- Remove the protective tape covering the inlet collar prior to connecting the ductwork.
- Provide at least 48 inches after the discharge prior to any transition for optimum flow control.
- Units (with electric heat) **MUST** be installed such that a minimum of 48 inches of full-size, straight duct is connected before any elbows, filters, transitions or any other downstream air disturbance.
- Connecting duct should be configured and installed in accordance with SMACNA guidelines and local code requirements.
- Inlet duct should be the same size as unit inlet. Straight, solid (non-flexible) duct will yield the best airflow and acoustical performance.
- Slide duct over inlet collar, fasten and seal in accordance with the project plans. Provide insulation over the entire inlet collar, while allowing clearance for the flow sensor tubing.
- After all duct connections are made, check that the entire ductwork system is airtight.

## Hot Water Connections (when applicable)

- Hot water heating coils require a field sweat connection to control valve(s) and water supply. Refer to unit construction submittal drawing for specific connection size. Use appropriate brazing alloy for connection.
- The hot water coil is provided in either a right or left hand connection configuration. If necessary, the coil can be rotated 180 degrees for the opposite hand connection.
- Inlet water temperature should not exceed 200°F per UL 1995.

## Electrical Connections

**NOTE:** The manual was written with the understanding that the line power and control wiring drawings submitted for the specific project have been acquired and are available during installation.

- Electrical wiring, connections, fusing and installation must conform to the local building codes and the NATIONAL ELECTRIC CODE.
- For terminal with electric heat, check the unit wiring diagram for single or dual point connection for electric heater and fan motor voltage.
- The fan terminal I.D. label lists Maximum Overcurrent Protection (MOP) for single point connection fan terminals that have loads consisting of both blower motor and electric heater. This is considered a motor group installation. For these units, the supply circuit must be fused individually.
- UL standards dictate that the power source must be within 10% of nameplate voltage, for safety and longevity. If incoming voltage is 10% above or below nameplate voltage, contact power Company to correct before operating terminal.
- The supply circuit can be fused external to the unit by the installer. The electric heater may be specified with primary circuit fusing which would not require external fusing.
- If the blower motor is the only load, the MOP value on the fan terminal label is blank. In this case, the units may be field wired for multiple hookups from a single branch circuit, as specified by the National Electric Code/Canadian Electric Code and Local Codes.
- Only special HACR-type circuit breakers may be used in place of fusing for over current protection of motor group installations.
- To determine the minimum wire size for terminals without electric heat, use the motor amperage listed on the fan terminal label. The label lists the Minimum Circuit Ampacity (MCA) to determine the proper size for units with electric heat. The power supply wiring is to be sized in accordance with the National Electric Code/Canadian Electric Code and Local Codes.
- The power supply terminal block is for use with copper conductors only.
- Field installed electrical components must be mounted and wired per factory supplied wiring diagram. Factory wiring must not be altered without written approval from ANEMOSTAT; violation of this will void warranty.

### **For fan terminals provided with electric heating coil: note these additional instructions:**

- Connect the fan terminal as shown on the heater wiring schematic diagram found inside the heater wiring enclosure, and also per interlocking VAV controls where applicable.
- The minimum airflow allowed is 70 CFM per KW of electric heat.
- 480 volt/3 phase coils may incorporate "wye" or other unbalanced configuration for multiple steps.



## QSTE – Electric Heat

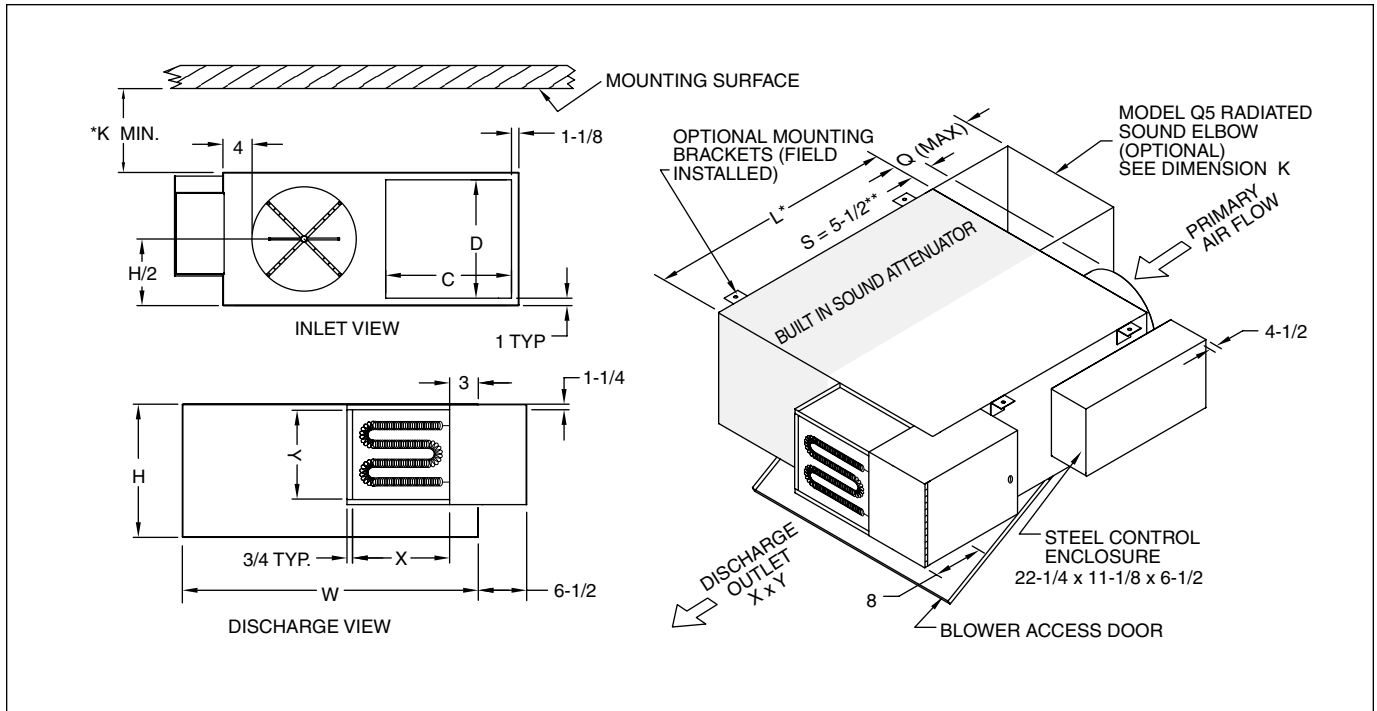

Model Number QSTE	Motor H.P.	Nominal Inlet Diameter	Height H	Width W	Length L	Min. K	Discharge		Induction		Q	Est. Wt. LB
							X	Y	C	D		
1706, 1707, 1708	1/6	6,7,8	18	32	36	6	11-1/2	11	12	16	18	142
2508, 2509, 2510	1/4	8,9,10	18	32	36	6	11-1/2	11	12	16	18	146
5010, 5012, 5014	1/2	10,12,14	18	40	40	6	14	12	17	16	18	162
7512, 7514	3/4	12,14	20	48	48	8	19	16	21	18	20	217
1012, 1014, 1016	1	12,14,16	20	48	48	8	19	16	21	18	20	224

### Notes

Weights are an estimate and will vary based on selection options, insulation type, etc.

- 36" clearance required by NEC for electrical enclosures.
- Add 1" to L dimension and \*\*reduce dimension S to 4-1/2" for double wall and low temperature option.
- \*K dimension required with optional Q5 sound elbow.



## QSTW – Water Heat

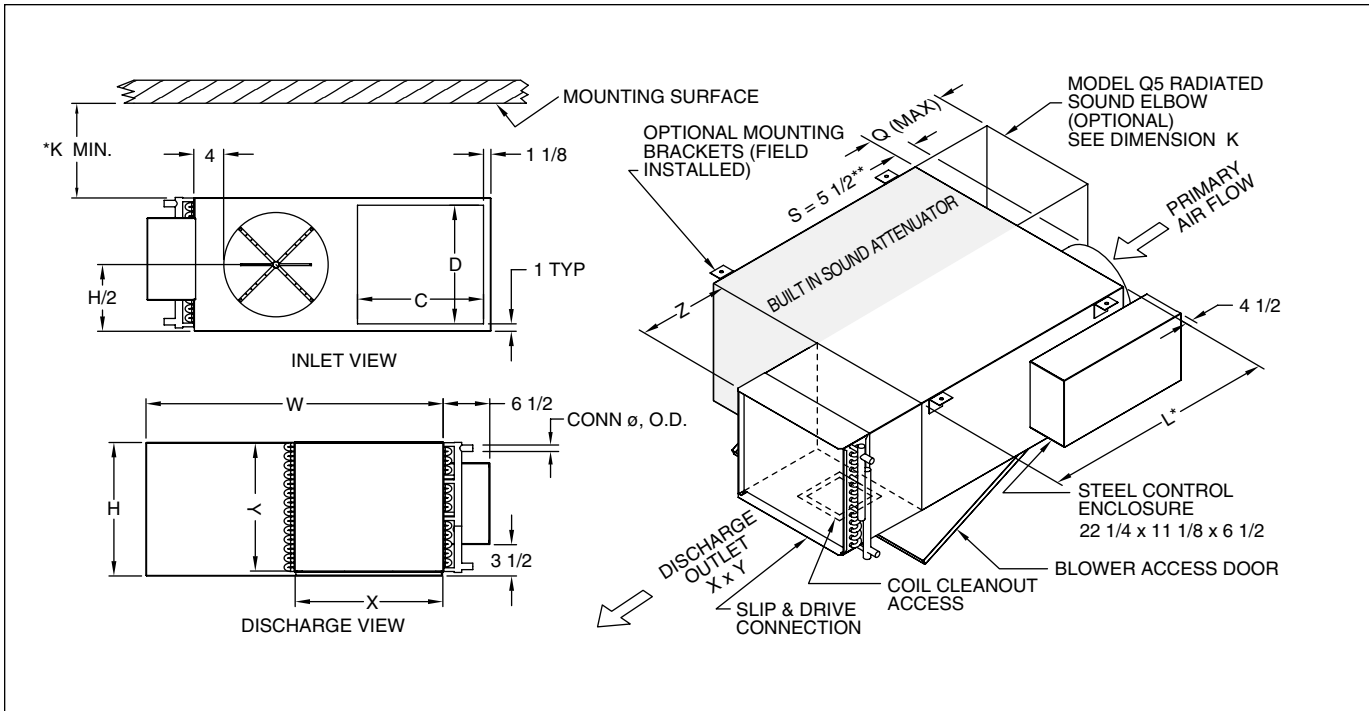

Model Number QSTW	Motor H.P.	Nominal Inlet Diameter	Height H	Width W	Length L	Min. K	Discharge		Induction		1 ROW COIL			2 ROW COIL			
							X	Y	C	D	Q	Z	LB	CONN ø	Z	LB	CONN ø
1706, 1707, 1708	1/6	6,7,8	18	32	36	6	16	15	12	16	18	12 1/4	133	7/8	13 1/2	137	1/2
2508, 2509, 2510	1/4	8,9,10	18	32	36	6	20	17 1/2	12	16	18	12 1/4	138	7/8	13 1/2	141	7/8
5010, 5012, 5014	1/2	10,12,14	18	40	40	6	20	17 1/2	17	16	18	12 1/4	159	7/8	13 1/2	164	7/8
7512, 7514	3/4	12,14	20	48	48	8	24	17 1/2	21	18	20	12 1/4	207	7/8	13 1/2	212	7/8
1012, 1014, 1016	1	12,14,16	20	48	48	8	24	17 1/2	21	18	20	12 1/4	211	7/8	13 1/2	217	7/8

### Notes

Weights are an estimate and will vary based on selection options, insulation type, etc.

- 36" clearance required by NEC for electrical enclosures.
- Add 1" to L dimension and \*\*reduce dimension S to 4-1/2" for double wall and low temperature option.
- \*K dimension required with optional Q5 sound elbow.



## ESTS – Standard

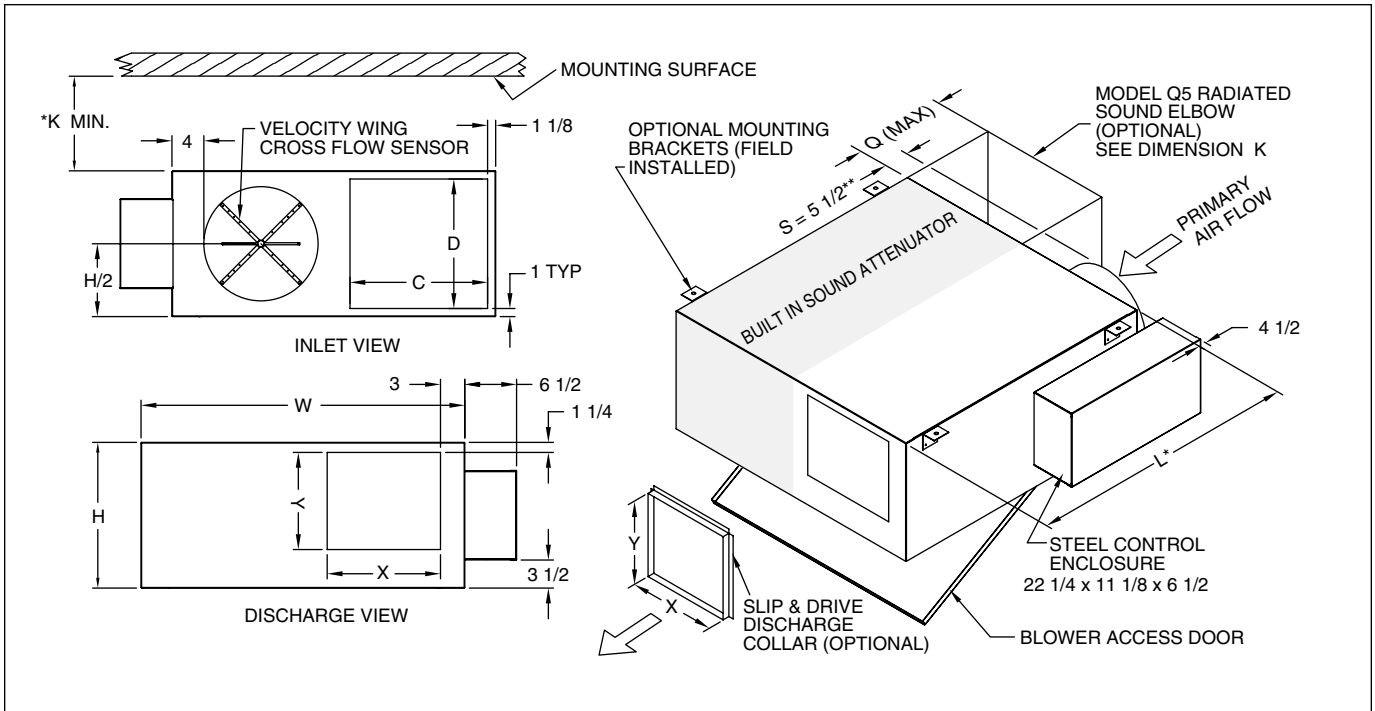

Model Number ESTS	Motor H.P.	Nominal Inlet Diameter	Height H	Width W	Length L	Min. K	Discharge		Induction			Est. Wt. LB
							X	Y	C	D	Q	
3306, 3307, 3308 3309, 3310	1/3	6, 7, 8, 9, 10	18	32	36	6	11 1/2	11	12	16	18	124
5006, 5007, 5008, 5009 5010, 5012, 5014	1/2	6, 7, 8, 9 10, 12, 14	18	40	40	6	14	12	17	16	18	139
7507, 7508, 7509 7510, 7512, 7514	3/4	7, 8, 9 10, 12, 14	20	48	48	8	19	16	21	18	20	187
1009, 1010, 1012 1014, 1016	1	9, 10, 12 14, 16	20	48	48	8	19	16	21	18	20	191

### Notes

Weights are an estimate and will vary based on selection options, insulation type, etc.

- 36" clearance required by NEC for electrical enclosures.
- Add 1" to L dimension and \*\*reduce dimension S to 4-1/2" for double wall and low temperature option.
- \*K dimension required with optional Q5 sound elbow.



## ESTE – Electric Heat

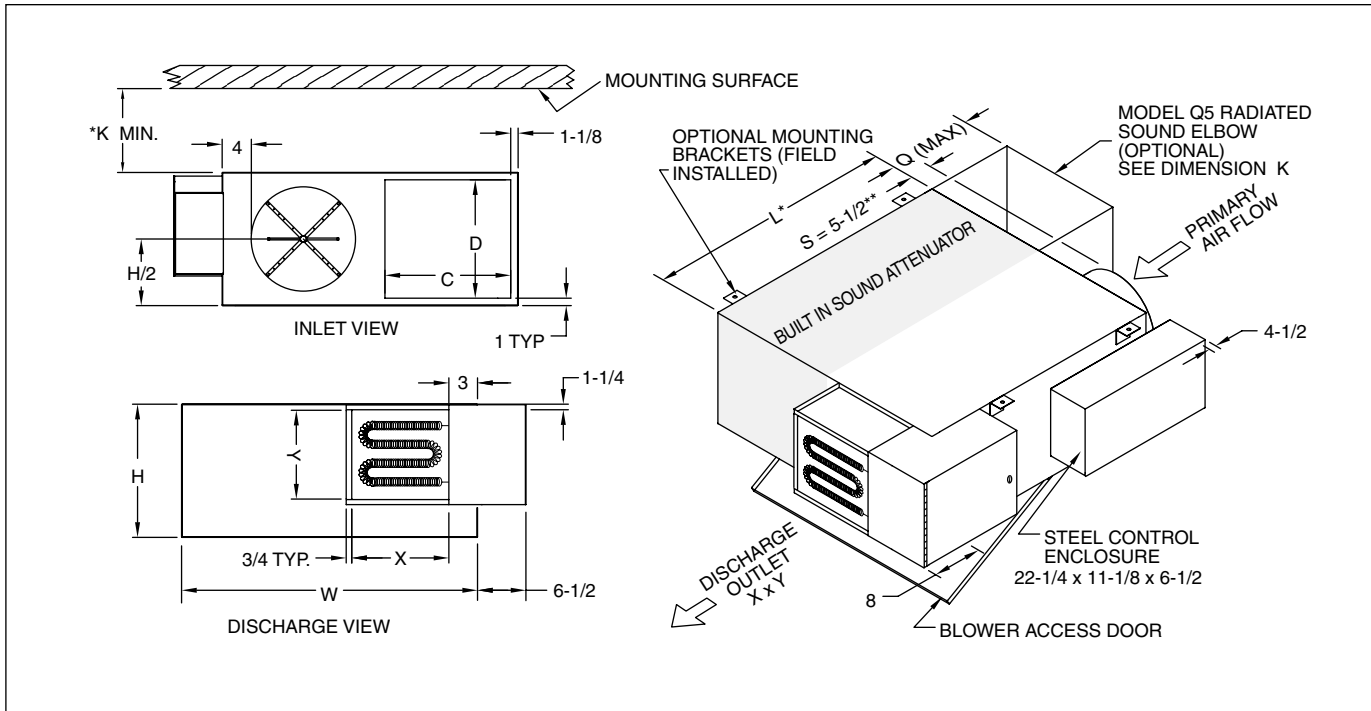

Model Number ESTE	Motor H.P.	Nominal Inlet Diameter	Height H	Width W	Length L	Min. K	Discharge		Induction		Q	Est. Wt. LB
							X	Y	C	D		
3306, 3307, 3308 3309, 3310	1/3	6, 7, 8, 9, 10	18	32	36	6	11-1/2	11	12	16	18	146
5006, 5007, 5008, 5009 5010, 5012, 5014	1/2	6, 7, 8, 9 10, 12, 14	18	40	40	6	14	12	17	16	18	162
7507, 7508, 7509 7510, 7512, 7514	3/4	7, 8, 9 10, 12, 14	20	48	48	8	19	16	21	18	20	217
1009, 1010, 1012 1014, 1016	1	9, 10, 12 14, 16	20	48	48	8	19	16	21	18	20	224

### Notes

Weights are an estimate and will vary based on selection options, insulation type, etc.

- 36" clearance required by NEC for electrical enclosures.
- Add 1" to L dimension and \*\*reduce dimension S to 4-1/2" for double wall and low temperature option.
- \*K dimension required with optional Q5 sound elbow.



# ESTW – Water Heat

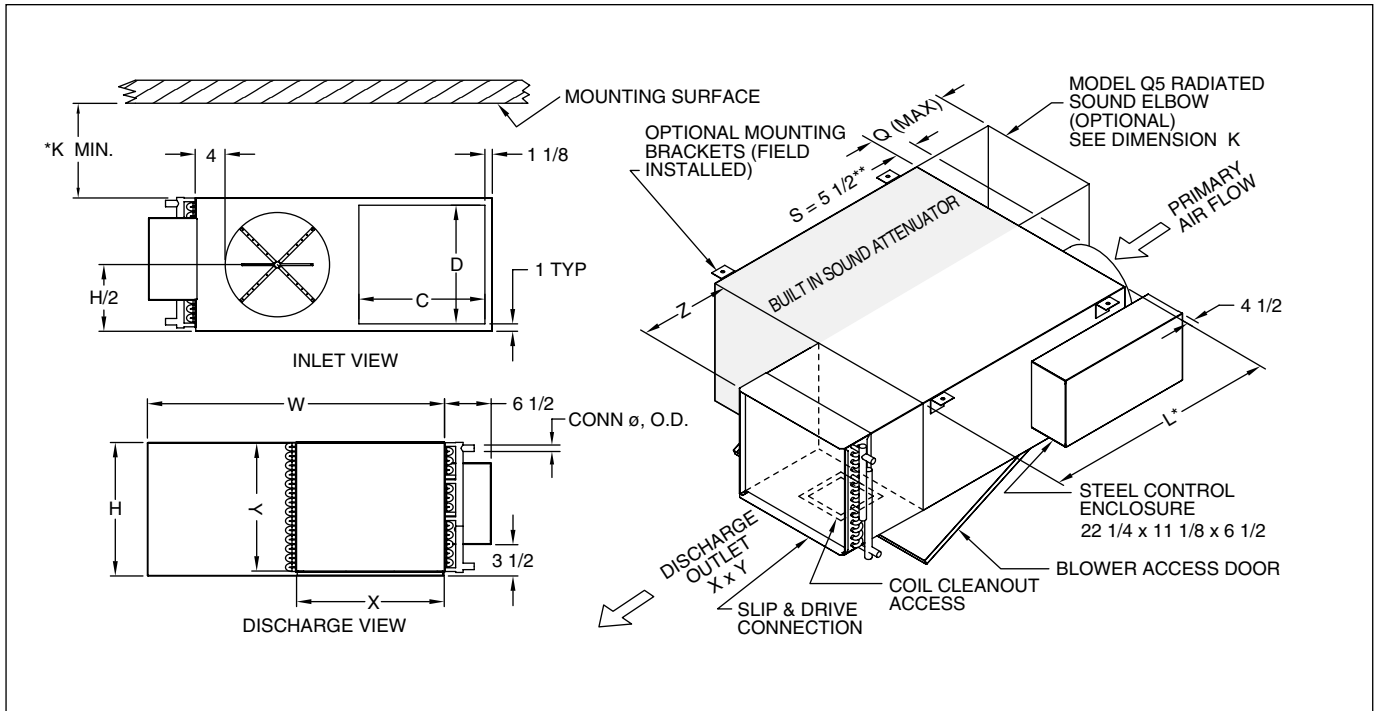

Model Number ESTW	Motor H.P.	Nominal Inlet Diameter	Height H	Width W	Length L	Min. K	Discharge		Induction			1 ROW COIL			2 ROW COIL		
							X	Y	C	D	Q	Z	LB	CONN ø	Z	LB	CONN ø
3306, 3307, 3308 3309, 3310	1/3	6, 7, 8 9, 10	18	32	36	6	20	17 1/2	12	16	18	12 1/4	138	7/8	13 1/2	141	7/8
5006, 5007, 5008, 5009 5010, 5012, 5014	1/2	6, 7, 8, 9 10, 12, 14	18	40	40	6	20	17 1/2	17	16	18	12 1/4	159	7/8	13 1/2	164	7/8
7507, 7508, 7509 7510, 7512, 7514	3/4	7, 8, 9, 10, 12, 14	20	48	48	8	24	17 1/2	21	18	20	12 1/4	207	7/8	13 1/2	212	7/8
1009, 1010, 1012 1014, 1016	1	9, 10, 12 14, 16	20	48	48	8	24	17 1/2	21	18	20	12 1/4	211	7/8	13 1/2	217	7/8

## Notes

Weights are an estimate and will vary based on selection options, insulation type, etc.

- 36" clearance required by NEC for electrical enclosures.
- Add 1" to L dimension and \*\*reduce dimension S to 4-1/2" for double wall and low temperature option.
- \*K dimension required with optional Q5 sound elbow.



## QPTS – Standard

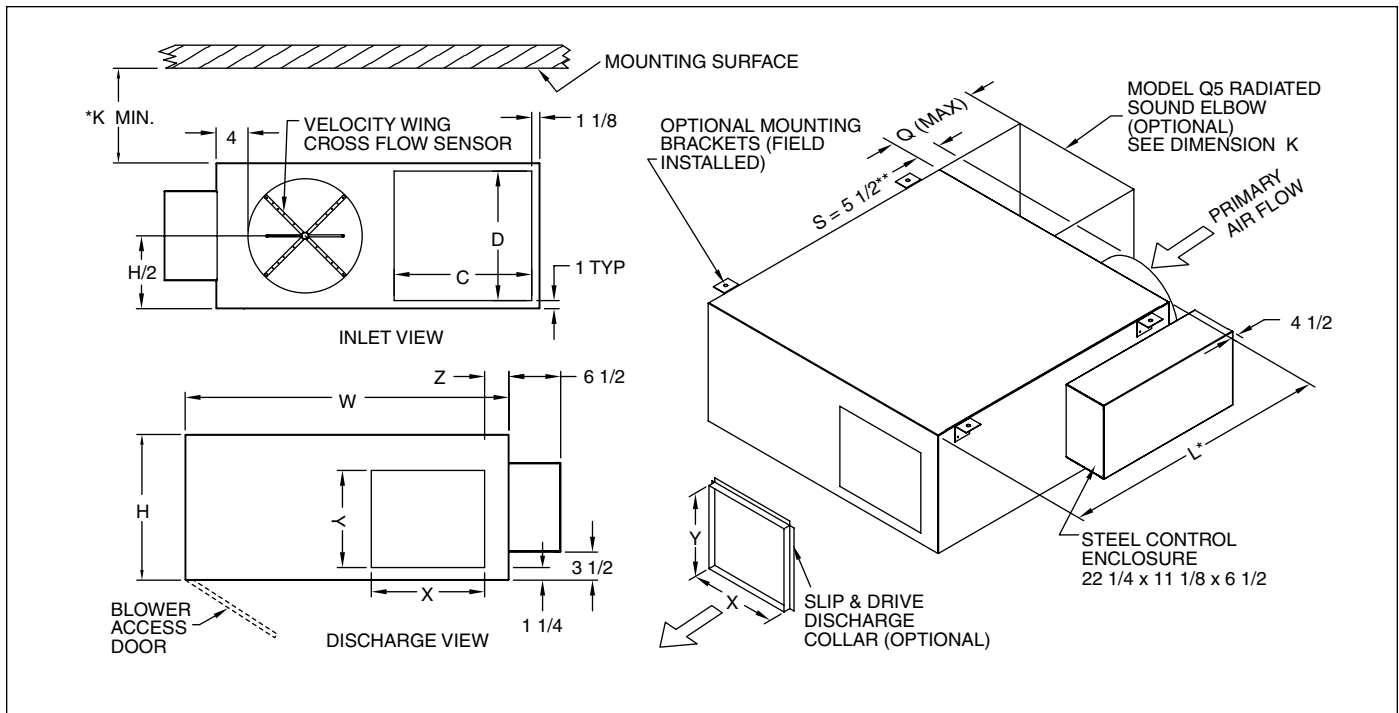

Model QPTS Size	Cabinet Size	Motor H.P.	Nominal Inlet Diameter	H	W	L	Min. K	Discharge			Induction			Est. Wt. LB
								X	Y	Z	C	D	Q	
11706, 11707, 11708, 11709	1	1/6	6, 7, 8, 9	15	34	30	6	11-1/2	11	3	13	12	18	83
12506, 12507, 12508, 12509	1	1/4	6, 7, 8, 9	15	34	30	6	11-1/2	11	3	13	12	18	86
21709, 21710, 21712	2	1/6	9, 10, 12	18	40	34	6	14	12	3	17	16	18	100
22509, 22510, 22512	2	1/4	9, 10, 12	18	40	34	6	14	12	3	17	16	18	105
25009, 25010, 25012	2	1/2	9, 10, 12	18	40	34	6	14	12	3	17	16	18	110
35012, 35014, 35016	3	1/2	12, 14, 16	20	46	40	8	19	16	2-1/4	21	18	20	134
37512, 37514, 37516	3	3/4	12, 14, 16	20	46	40	8	19	16	2-1/4	21	18	20	139
31012, 31014, 31016	3	1	12, 14, 16	20	46	40	8	19	16	2-1/4	21	18	20	146

### Notes

Weights are an estimate and will vary based on selection options, insulation type, etc.

- 36" clearance required by NEC for electrical enclosures.
- Add 1" to L dimension and \*\*reduce dimension S to 4-1/2" for double wall and low temperature option.
- \*K dimension required with optional Q5 sound elbow.



## QPTE – Electric Heat

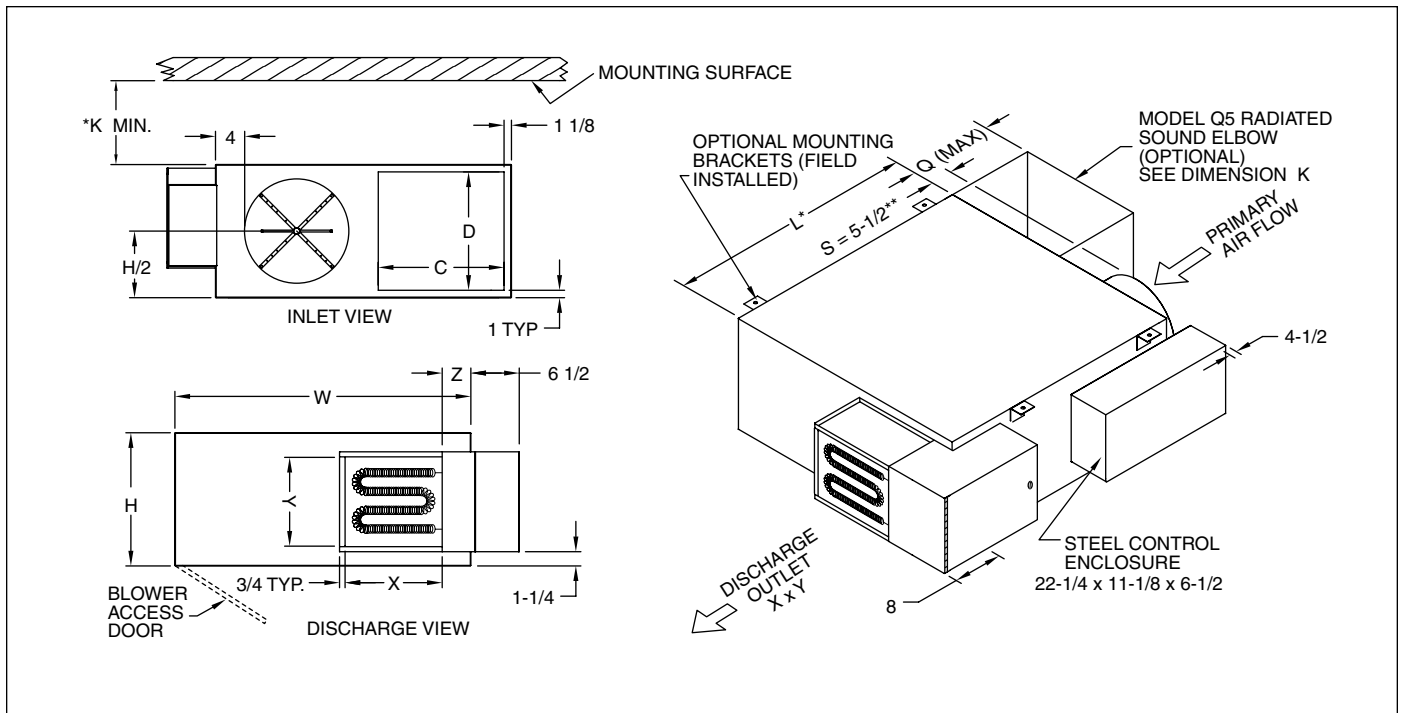

Model QPTE Size	Cabinet Size	Motor H.P.	Nominal Inlet Diameter	H	W	L	Min. K	Discharge			Induction			Est. Wt. LB
								X	Y	Z	C	D	Q	
11706, 11707, 11708, 11709	1	1/6	6,7,8,9	15	34	30	6	11-1/2	11	3	13	12	18	108
12506, 12507, 12508, 12509	1	1/4	6,7,8,9	15	34	30	6	11-1/2	11	3	13	12	18	111
21709, 21710, 21712	2	1/6	9,10,12	18	40	34	6	14	12	3	17	16	18	123
22509, 22510, 22512	2	1/4	9,10,12	18	40	34	6	14	12	3	17	16	18	128
25009, 25010, 25012	2	1/2	9,10,12	18	40	34	6	14	12	3	17	16	18	133
35012, 35014, 35016	3	1/2	12,14,16	20	46	40	8	19	16	2-1/4	21	18	20	167
37512, 37514, 37516	3	3/4	12,14,16	20	46	40	8	19	16	2-1/4	21	18	20	172
31012, 31014, 31016	3	1	12,14,16	20	46	40	8	19	16	2-1/4	21	18	20	179

### Notes

Weights are an estimate and will vary based on selection options, insulation type, etc.

- 36" clearance required by NEC for electrical enclosures.
- Add 1" to L dimension and \*\*reduce dimension S to 4-1/2" for double wall and low temperature option.
- \*K dimension required with optional Q5 sound elbow.



## QPTW – Water Heat

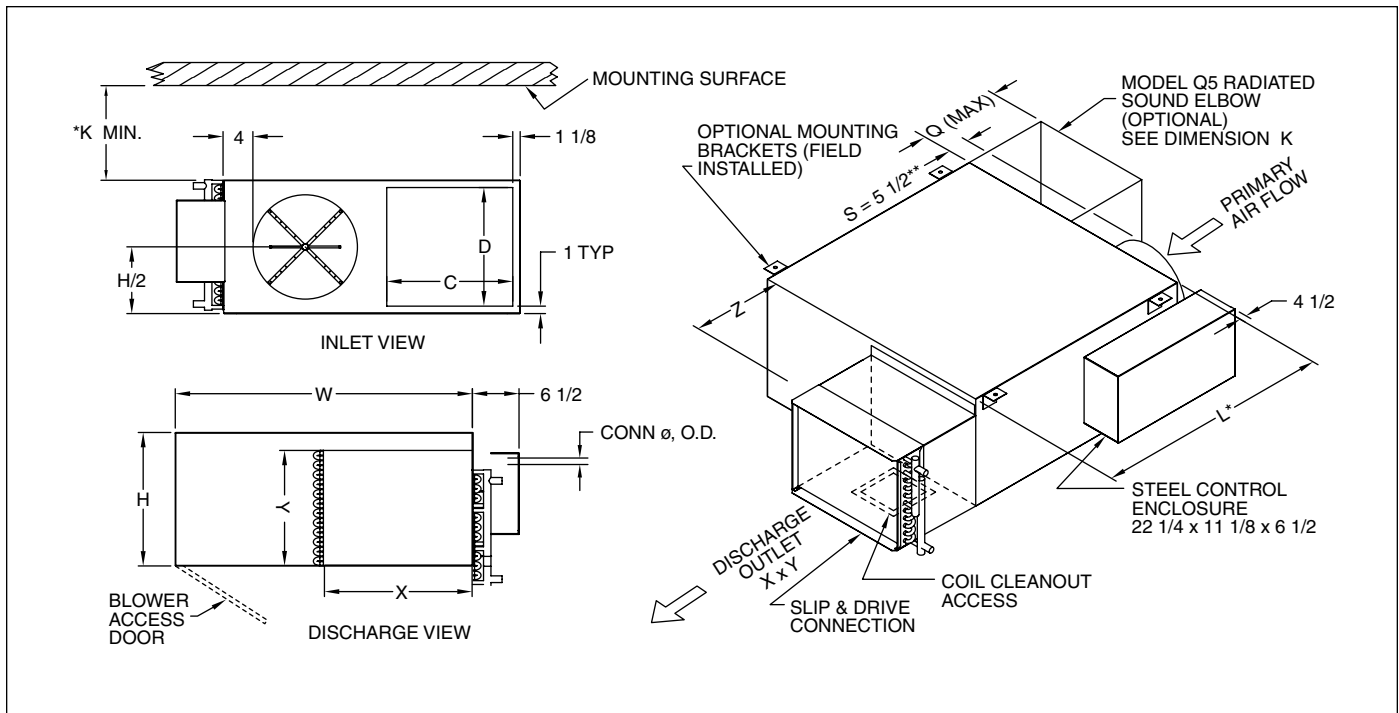

Model QPTW Size	Cabinet Size	Motor H.P.	Nominal Inlet Diameter	H	W	L	Min. K	Discharge		Induction			1 ROW COIL			2 ROW COIL		
								X	Y	C	D	Q	Z	LB	CONN ø	Z	LB	CONN ø
11706, 11707, 11708, 11709	1	1/6	6,7,8,9	15	34	30	6	16	15	13	12	18	12-1/4	99	7/8	13-1/2	103	1/2
12506, 12507, 12508, 12509	1	1/4	6,7,8,9	15	34	30	6	16	15	13	12	18	12-1/4	102	7/8	13-1/2	106	1/2
21709, 21710, 21712	2	1/6	9,10,12	18	40	34	6	20	17-1/2	17	16	18	12-1/4	114	7/8	13-1/2	117	7/8
22509, 22510, 22512	2	1/4	9,10,12	18	40	34	6	20	17-1/2	17	16	18	12-1/4	119	7/8	13-1/2	122	7/8
25009, 25010, 25012	2	1/2	9,10,12	18	40	34	6	20	17-1/2	17	16	18	12-1/4	124	7/8	13-1/2	127	7/8
35012, 35014, 35016	3	1/2	12,14,16	20	46	40	8	24	17-1/2	21	18	20	12-1/4	154	7/8	13-1/2	160	7/8
37512, 37514, 37516	3	3/4	12,14,16	20	46	40	8	24	17-1/2	21	18	20	12-1/4	159	7/8	13-1/2	165	7/8
31012, 31014, 31016	3	1	12,14,16	20	46	40	8	24	17-1/2	21	18	20	12-1/4	166	7/8	13-1/2	172	7/8

### Notes

Weights are an estimate and will vary based on selection options, insulation type, etc.

- 36" clearance required by NEC for electrical enclosures.
- Add 1" to L dimension and \*\*reduce dimension S to 4-1/2" for double wall and low temperature option.
- \*K dimension required with optional Q5 sound elbow.



## General Controller Information

### Notes:

1. Minimum airflow with pressure independent controls based on the following minimum flow sensor signals:  
5000-series - 1 VDC (see table 2)  
3000-series - 0.03" w.g.
2. Pressure independent controls may be set for 0 CFM, at or above the minimum airflow shown, but not between.
3. 3000 series can be used either as direct or reverse acting for normally open or normally closed damper positions. Field adjustable start point and reset span. The 3000 series is equipped with separate adjustable knobs for maximum and minimum airflow settings.
4. 5000 series maximum and minimum airflow settings field adjustable at the thermostat.

REFER TO THE DOCUMENTATION PROVIDED ON THE WIRING/PIPING DIAGRAM ON THE TERMINAL FOR THE PROPER FIELD ADJUSTMENT OF THE MINIMUM AND MAXIMUM AIRFLOW SETTINGS ON TERMINALS PROVIDED WITH PRESSURE INDEPENDENT CONTROLS.

### Some adjusting tips:

1. Allow sufficient time for the controller to respond to adjustments.
2. Cycling of the thermostat to check maximum and minimum airflow settings is often required.
3. On units with pneumatic controls, do not turn the adjustment knobs excessively.

## Pneumatic Connections

1. Main air is supplied to the primary control box through the hole marked M. The thermostat is connected through the hole marked T. The air flow measuring tubes are factory connected through the holes marked L and H.
2. Terminals that use pneumatic controls require a 20-30 psi supply of clean, dry, oil-free air.

## Model 31 Pneumatic Controller

### (Pneumatic Controls)

A pressure gauge or manometer is required for flow adjustment. Refer to Calibration Table 1 on the following page.

1. Connect pressure gauge or inclined manometer to the primary air flow taps. The upstream flow tap is connected to the high pressure side of the gauge. The downstream flow tap is connected to the low pressure side of the gauge.
2. Refer to the Calibration Table for the pressure reading at the required CFM.

## Primary Air Flow Adjustment

The thermostat-reset span is factory set at 5.0 psi. To field adjust the reset span follow these steps:

1. Remove the gauge tap cap at G and attach the 0-30 psi gauge.
2. Adjust the thermostat pressure to the T port to 20 psi.
3. Adjust the RESET SPAN knob until the gauge G pressure is equal to the desired reset span. This is total span pressure, not ending span pressure.
4. Replace the gauge tap cap.

For Normally Open or Normally Closed dampers with either Direct or Reverse Acting thermostats, follow these steps:

1. The LO STAT is always calibrated first, with 0 psi on the T port. This air flow setting will be the desired minimum for DA/Cooling or RA/Heating applications, or the maximum for RA/Cooling or DA/Heating.
2. The HI STAT is always calibrated second with 20 psi on the T port. This air flow setting will be the desired maximum of DA/Cooling or RA/Heating applications, or the minimum for RA/Cooling or DA/Heating applications.

**NOTE:** The minimum inlet static pressure, as shown on the performance data charts, is required for proper operation.

**Table 1 – Airflow vs. Velocity Wing™ Signal**  
(Non-Flow Thru / Dead Head)

Sensor dP	Inlet Size							
	6	7	8	9	10	12	14	16
	<b>CFM</b>							
<b>0.03</b>	81	106	150	190	234	312	428	583
<b>0.04</b>	94	122	173	220	271	360	494	673
<b>0.06</b>	115	150	212	269	331	441	605	824
<b>0.1</b>	148	194	274	347	428	570	781	1064
<b>0.2</b>	210	274	388	491	605	806	1104	1505
<b>0.3</b>	257	335	475	601	741	987	1352	1844
<b>0.4</b>	297	387	548	694	856	1140	1562	2129
<b>0.5</b>	332	433	613	776	957	1274	1746	2380
<b>0.6</b>	363	474	672	851	1048	1396	1912	2607
<b>0.7</b>	392	512	725	919	1132	1508	2066	2816
<b>0.8</b>	419	547	775	982	1210	1612	2208	3011
<b>0.9</b>	445	581	823	1042	1284	1710	2342	3193
<b>1 (K-Factor)</b>	<b>469</b>	<b>612</b>	<b>867</b>	<b>1098</b>	<b>1353</b>	<b>1802</b>	<b>2469</b>	<b>3366</b>
<b>1.5</b>	574	750	1062	1345	1657	2207	3024	4122

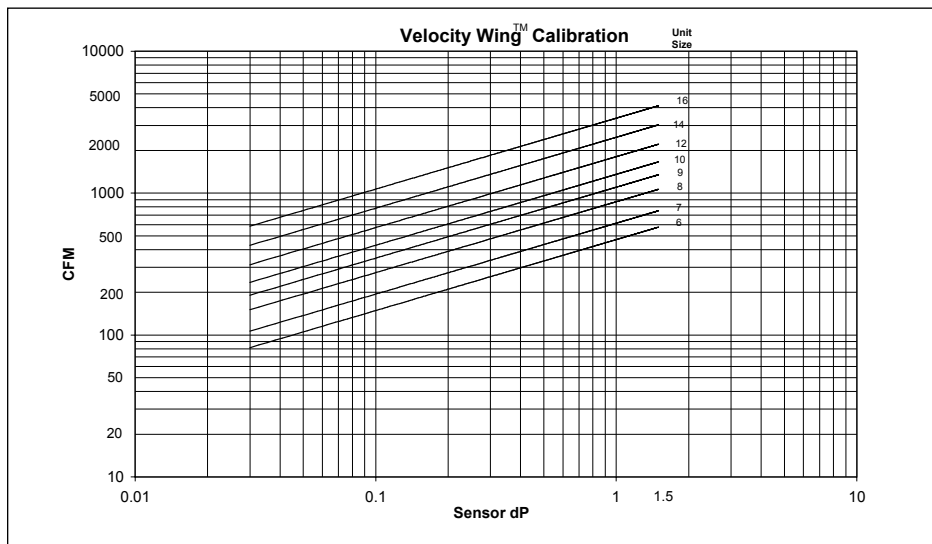

## Electric Analog Connections

Electronic controls are typically factory wired for single point power voltage supply with fan relay and 24VAC power (from a step-down transformer) as part of the fan circuit or electric heater circuit.

1. The remote mounted thermostat is connected to the appropriate components located in the control box. See the control wiring diagram affixed to the inside of cover.
2. When hot water reheat is used, the relay in the control box must be wired to the water valve actuator.

## Electronic DDC Controls

(Factory-mounted, controls by others)

**IMPORTANT** All RS485 communication networks must be installed using twisted, shielded pair wiring. Each twisted pair must be individually shielded. If using unshielded wiring, cables must be placed in solid metal conduit alone, without DC switching or AC lines. Failure to use these types of connectors may result in various system communication problems such as excessive network retries, noise susceptibility, and loss of communication.

If proper wiring is not used, the site may not meet FCC class A regulations for RFI emissions; thereby forcing the installer or user to make the necessary wiring changes at a later date.

## Primary Air Flow Adjustment (Electric Analog Controls - Series CSP-5000)

Maximum and minimum flow limits can be field-adjusted without the use of additional measuring equipment. Adjustment is made with a Digital Voltmeter (DVM) at room thermostat without accessing the air terminal. The electronic thermostat is a low voltage solid-state thermistor device, with very rapid (almost instantaneous) response to temperature changes in the conditioned space.

To adjust the maximum and minimum flow limits; a small flat blade (1/8") screwdriver and a digital voltmeter (0-10VDC in .01 of VDC) are required. In addition, the ambient room temperature at the thermostat must be within 55-85F for proper calibration.

1. Remove the thermostat cover by releasing the spring clips on both sides of the thermostat.
2. Plug the voltmeter into the thermostat meter taps.
3. Adjust the cooling setpoint slider all the way to the right for minimum cooling. Adjust the MIN INCR potentiometer to the desired DC voltage (Reference the DC voltage vs. the CFM curve in Table 2). The minimum setpoint must be adjusted first.
4. Adjust the cooling setpoint slider all the way to the left for maximum cooling. Adjust the MAX INCR potentiometer to the desired DC voltage (Reference DC voltage vs. CFM curve in Table 2). The maximum setpoint must be adjusted last.

**Table 2 – Airflow vs. Velocity Wing™ Signal  
(Analog Controls - Series CSP-5000)**

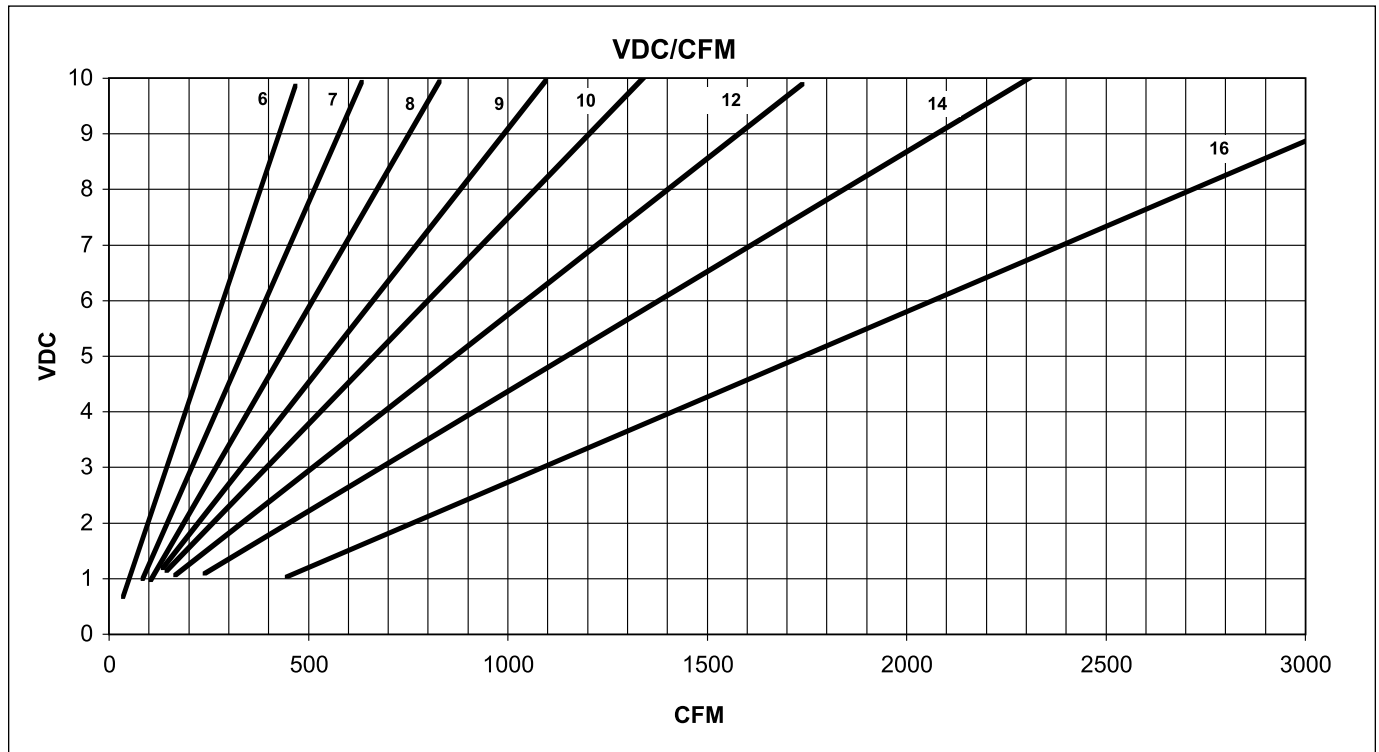

**NOTE:** The minimum inlet static pressure, as shown on the performance data literature, is required for proper operation.

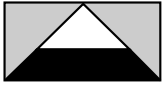

## Altitude Correction Factors

Barometric Pressure (in h.g.)	Altitude (feet)	Density lb/ft <sup>3</sup>	Correction Factor
29.92	0	.075	1.03
20.28	500	.074	1.01
28.85	1000	.072	0.99
28.33	1500	.071	0.98
27.82	2000	.070	0.96
27.32	2500	.068	0.95
26.81	3000	.067	0.93
26.33	3500	.066	0.91
25.84	4000	.065	0.89
25.37	4500	.064	0.88
24.89	5000	.062	0.86
24.44	5500	.061	0.85
23.98	6000	.060	0.83
23.54	6500	.059	0.82
23.09	7000	.058	0.80

**Example:** Determine the airflow sensor signal of a 6" unit at 500 CFM located at an elevation of 5000 ft., for a 3000 series pneumatic controller.

To use the correction factor:

$$\text{Correction factor} \times \text{CFM at unit location} = .86 \times 500 = 430 \text{ CFM}$$

Referencing the 6" flow curve, shown on page 10, find 430 CFM @ .80" w.c. sensor signal pressure. The velocity controller set at .80" signal pressure will result in 500 CFM at 5000 ft. elevation.

## Fan Discharge Air Flow Adjustment

Two levels of adjustment are allowed

1. Motor HP (course)
2. SCR (fine)

Three motor (HP) taps are wired into the control enclosure to a terminal block. Factory default is the high tap (labeled "H"). Do not operate unit without ductwork, as motor overload and failure may occur. During final balancing, adjustment of the motor horsepower may be made inside the control enclosure, by moving the red (line-side wire from the SCR) to a different terminal (either "M" - Medium or "L" - Low).

**NOTE: Disconnect power before switching motor taps.**

A small flat blade 1/8" screwdriver is required to adjust the fan discharge airflow via the SCR. The adjustment screw is located through a small hole in the bottom of the control enclosure. You do not need to open the enclosure for this fan speed adjustment.

1. Fan discharge airflow is field-adjusted by varying the downstream static pressure, adjusting the motor HP taps and finally, the SCR speed controller.
2. Fan performance curves show the CFM for the various downstream static pressure (D.S.Ps) in inches of water. These are available from the Anemostat website.
3. Models QST and QPT fan terminals are designed to operate from .1 to .8 D.S.Ps. Motors may overload if terminals are operated at D.S.Ps below these limits. If terminals are operated at D.S.Ps above 0.8" w.g., freewheeling may result in possible motor damage.

## Table 4 – Unit Fan & Primary Flow Range Selection

**Model QST** (Note: Primary cfm may be reduced to the minimum controllable flow, but shall never exceed fan cfm.)

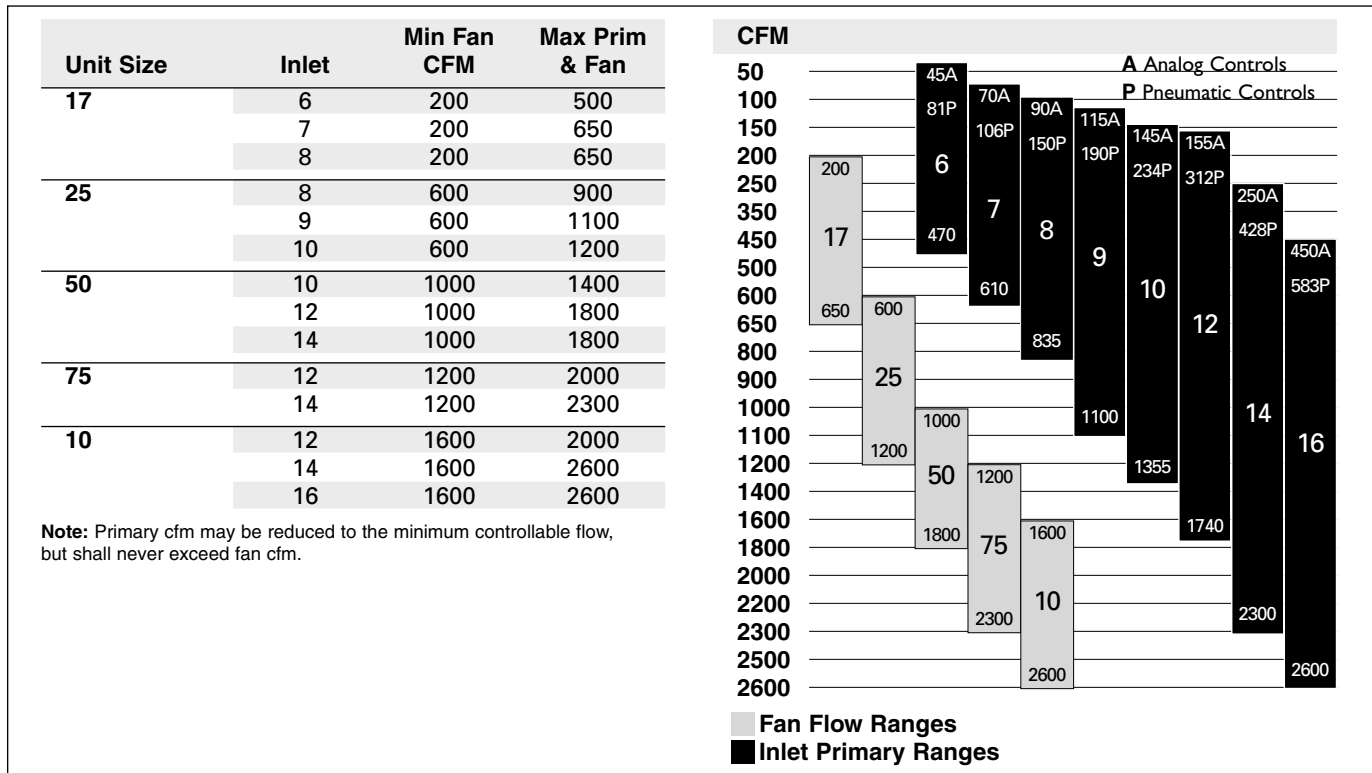

## Table 5 – Unit Fan & Primary Flow Range Selection

**Model EST**

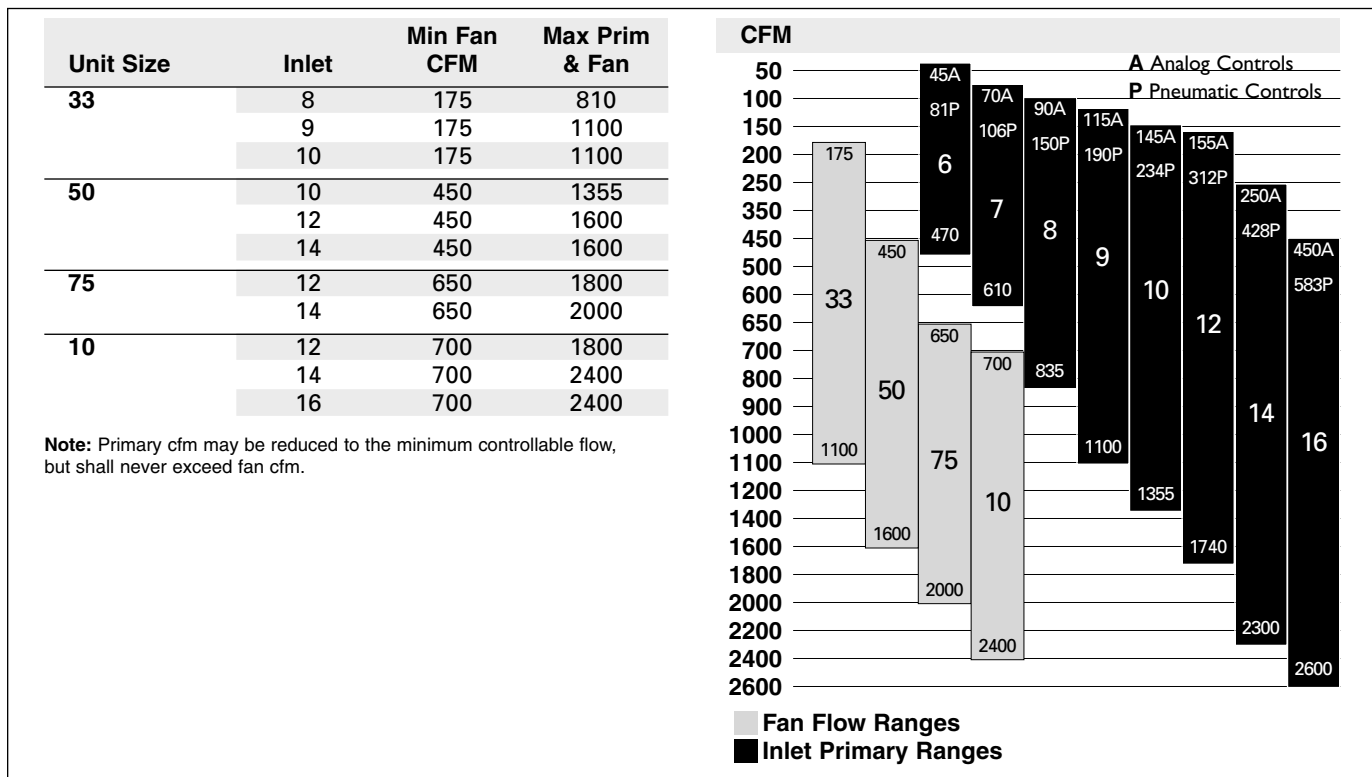

## Table 6 – Unit Fan & Primary Flow Range Selection

### Model QPT

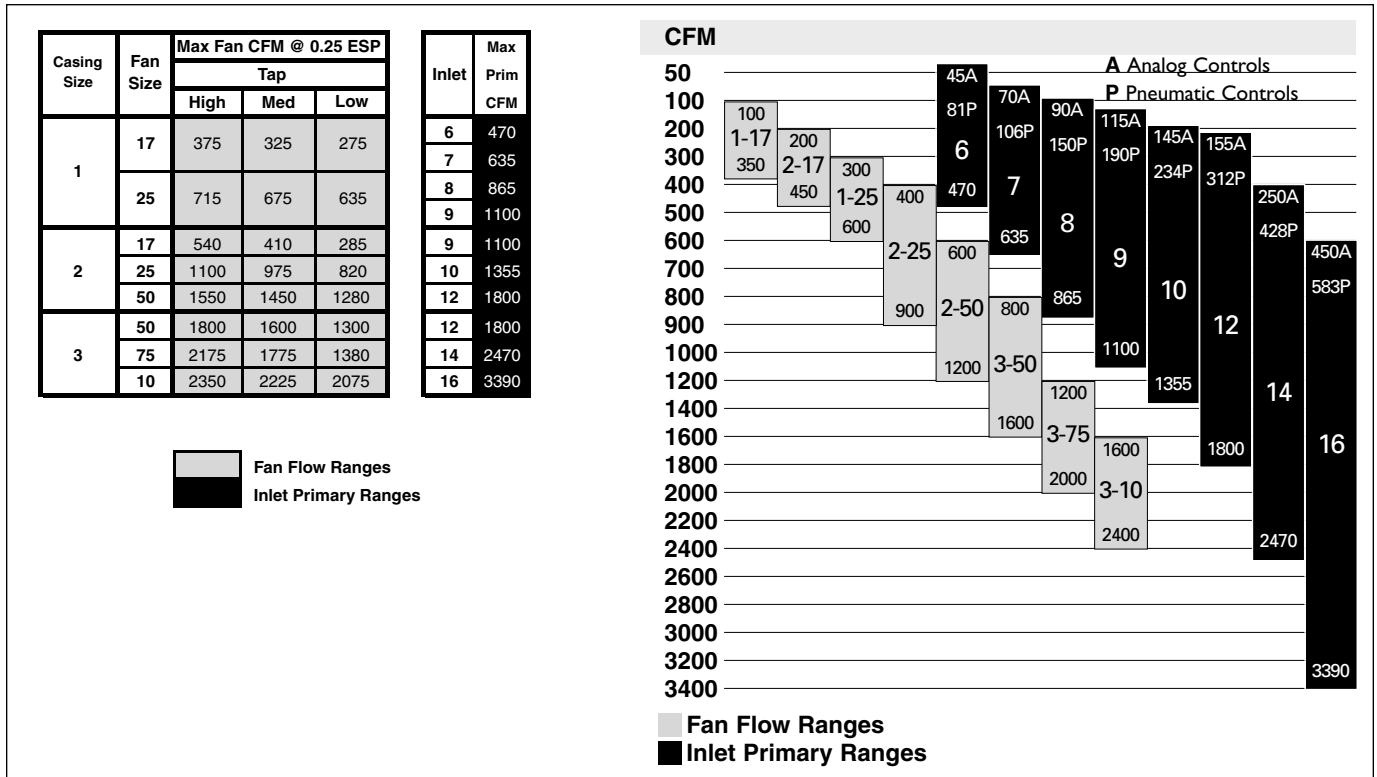

## Service & Replacement of Blower and/or Motor

Fan terminals have a bottom removal motor and blower. **The electric power must be disconnected before servicing the unit.** After the air terminal is de-energized, the procedures listed below must be followed.

1. Remove the blower motor access door from the terminal casing, by dropping the discharge end of the access door about 7 inches and lifting up on the inlet end.
2. Disconnect the blower motor wiring by removing the four spade connectors on the controls-side of the motor.
3. The motor and blower are removed as an assembly. Remove only the two nuts on the lower blower discharge. The assembly is "hooked" at the top of the discharge bulkhead. Swing the lower end of the blower assembly back and up to unhook, and drop down, out of the casing.
4. The blower and motor assembly can be bench serviced. The motor blower assembly is replaced by following the above steps in reverse order.

## Service & Replacement for Electrical & Pneumatic Parts

Fan Terminals have a control enclosure as a standard feature. The control enclosure houses the speed controller, motor relay, pneumatic electric (PE) switches, control transformer, air flow pressure switch, terminal blocks, disconnect switch, pneumatic or electric controller and the actuator that controls the inlet valve. A control-wiring diagram for each air terminal is attached to the unit. Individual components in the panels are not field-repairable. If one proves defective, it should be removed and a replacement component installed. See page 24 for replacement parts list.

## General Maintenance

Before performing any maintenance, disconnect power and allow the blower motor to come to a complete stop. Disconnect the capacitor for safety (located within the blower compartment). Dirt accumulation can cause motor overheating. Use a vacuum to remove dirt accumulations from the motor, especially in and around the motor vent openings.

The unit may be provided with a temporary air filter. The air filter is installed on the right, plenum-inlet side of the unit, into filter rails. Air filters should be replaced soon after fan terminal installation and start-up. Check the air filters regularly based on the condition of the operating environment and replace as necessary.

Periodically inspect and check for unusual noises or vibrations, high motor current, worn wiring, loose mounting bolts, and worn or pitted relay contacts.

The standard Fan Motors have permanently lubricated sleeve type bearings and require no oiling.

## General Troubleshooting

To troubleshoot suspected problems, a 0-1" w.g. Magnehelic, a voltmeter and a 0-20 psi pressure gauge are required.

- Be sure there is airflow through the terminal. The central (primary) fan must be on, the damper open, etc.
- Power must be supplied to the terminal. This includes line voltage to the fan circuit and transformer, 18 psi minimum to the pneumatic circuit, or 24VAC to the electronic circuit.

### Pneumatic Controls

If overcooling or undercooling occurs, the problem must be isolated as follows:

#### Tubing Connections

- Visually check the tubing connections and compare them with the proper control schematic. Check to be sure that each tube is tightly connected. Verify that 20 psi main air is available.

#### Thermostat

- Set the position of the thermostat temperature adjustment lever to the full cooling position. Connect the 0-1" w/g gauge to the balance tap and compare the signal pressure with the signal marked on the terminal label. These signals should be approximately equal.
- Move the lever to the minimum cooling position. If the thermostat is working properly, the inlet valve will close off causing the signal pressure to approach its minimum setpoint or zero.
- Results other than those above indicate a temperature adjustment must be made. Move the thermostat lever to a position slightly warmer or colder than the original setting.
- If the inlet valve does not reduce CFM when the thermostat is set for minimum cooling, check the pressure in the thermostat line. It should be 0 psi for a direct-acting thermostat and 20 psi for a reverse-acting thermostat. If the pressure is not as indicated, the thermostat may need to be replaced.

#### Pneumatic Motor (actuator)

- Check the motor for leaks and check the shaft setscrews to verify they have not come loose.

### CFM

Overcooling can also occur due to excessive CFM at minimum air setting. Ventilation air may have to be reduced or reheat added to maintain temperature control.

Undercooling may be an indication of insufficient duct pressure (air) and/or insufficient system cooling capacity. The following procedure is required:

- Check the inlet pressure to see that minimum pressure for CFM required is available at the terminal.
- Check the supply air cold duct temperature.

### Electronic Analog Controls

- Check for loose wires at the connections.
- Compare the control diagram located on the fan control access door to the wiring connections.
- Check for proper primary and secondary voltages.
- Verify that the supply voltage between the controller and the thermostat is approximately 16 VDC when measured between terminals 4 and 5. If not, the controller may need to be replaced.
- Verify the velocity sensor and duct pressure tubing is connected securely, taps are covered and no leakage is occurring.
- Verify the thermostat maximum and minimum potentiometer voltage. If minimum and maximum cannot be adjusted between 0 and 10 VDC, the thermostat may need to be replaced.

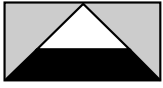

## Table 7 – Troubleshooting Guide

<b>Problem</b>	<b>Cause</b>	<b>Action</b>
<b>Motor does not Start</b>	Blown Fuse	Replace Fuse - Recheck
	Low voltage	Check/repair inadequate wiring or line power feed
	Improper line connections	Check against diagram and repair
	Defective Motor	Repair or replace
	Defective Capacitor	Replace
	Defective Speed Controller	Replace
<b>Motor Stalls</b>	Motor overloaded	Check for proper primary airflow, motor speed and HP setting
	Low Motor Voltage	Check for proper line voltage
<b>Motor does not reach full speed</b>	Voltage too low	Increase speed controller setting. Move to higher HP tap. Check for poor connections
	Starting load too high	Check primary airflow
<b>Motor takes too long to accelerate</b>	Excess loading or high inertia load	Check primary airflow, motor speed or HP tap setting. Clean blower wheel
	Applied voltage too low	Check for poor connections Increase conductor size
	Defective motor	Repair or replace
<b>Motor vibrates or is excessively noisy</b>	Motor misaligned	Realign
	Voltage too high	Check wiring; correct voltage
	Worn, damaged, dirty or overloaded bearings	Replace or repair motor; Check alignment and balance
<b>Motor overheats while running under load</b>	Overloaded motor	Check primary airflow
	Dirt clogging motor ventilation	Clean motor / blower
	Faulty connections	Clean tighten or repair wiring
	High or low voltage	Check for +/-10% rated voltage
	Defective Motor	Repair or Replace

## Troubleshooting EST Controllers (PWM)

EVO/ECM Series

Control Test Procedure

**Warning:** These tests are to be performed by qualified personnel who are familiar with the machinery where the EVO/ECM series control and connected motor is installed. All mechanical, electrical and other applicable safety practices must be observed when performing these tests. While the EVO/ECM series controls are low voltage devices, they are often installed in or near high voltage cabinets and wiring. And they are connected to electrically isolated connections on the ECM motor. Wiring and device faults can occur. Always test for high voltage before starting these tests!

High Voltage Fault Test *Perform this test in addition to all tests and practices prescribed by the equipment manufacturer and your professional training.*

1. Remove the machine's control cabinet cover or otherwise obtain access to the component side of the EVO/ECM series control. Leave everything connected. Typical Component Side →
2. If you removed power to gain access, re-power the equipment as necessary to troubleshoot the equipment.
3. Set the multimeter to measure AC Volts.
4. Connect the BLACK lead to electrical earth.
5. Touch the RED lead to the EVO/ECM series connection marked 24Vac. The meter should read about 30 Volts AC. If the meter reads a voltage above 48 Volts AC, immediately disconnect the machine. There is a high voltage fault somewhere in the system.
6. Touch the RED lead to the other connectors to the board. If the meter reads a voltage above 48 Volts AC, immediately disconnect the machine. There is a high voltage fault somewhere in the system.
7. Touch the RED lead to the metal wire grippers (top of connector) for each of the 4 motor wires. If the meter reads a voltage above 48 Volts AC, immediately disconnect the machine. There is a high voltage fault somewhere in the system.



Motor Control Connection →

You are ready to test the EVO/ECM series control.

## Troubleshooting EST Controllers (PWM) - continued

EVO/ECM Series

Control Test Procedure

---

This procedure allows you to test an EVO/ECM series GE ECM Motor control while it is powered and connected to the motor. The series includes many types of controls, all having the same interface to the ECM motor.

### Motor Interface

The EVO/ECM series uses a 4 wire interface to the motor. Most equipment uses our standard color coding for these wires:

Pin 1.	White	Motor On/Off	0 = Off, ~22Vdc = On
Pin 2.	Black	Tachometer	
Pin 3.	Green	Common	
Pin 4.	Red	Speed	0 = Min. Speed, ~22Vdc = Max. Speed

### Problem Solver:

ECM motor will not run.

Perform the Motor On test.

Motor Runs but the speed does not change.

Perform the Variable Speed Test.

Motor does not turn off.

Perform the Motor Off Test

Motor does not run unless power is removed and restored.

Perform Motor Off Test

Intermittent operation when connected to an automation system

Perform Motor Off Test

Motor Runs, but there is no RPM indication.

Perform the Tachometer Test

### A Fast Test.....

If the motor is not running and you want to determine if the EVO/ECM series control is calling for the motor to run, just measure the DC voltage between the Green and White wires on the motor control cable. If this voltage is greater than 10VDC, the motor should be running.

Especially if you measure this voltage at the connection to the motor. If you have an instance where the motor stops intermittently, and it restarts when power is removed then restored, perform this test before removing power. It will tell you if the intermittent part is the EVO/ECM series control!

---

## Troubleshooting EST Controllers (PWM) - continued

EVO/ECM Series

Control Test Procedure

**Motor On Test**      The *EVO/ECM series control must be set to ON to perform this test.*

Set the multimeter to read 24Vdc.

1. Touch the black lead to the common (Green) wire on the 4 pin motor connector.

2. Touch the red lead to the Motor On/Off (White) wire on the 4 pin motor connector.

3. If the Dc voltage is ~22Vdc, the motor should run.

4. If the motor does not run, the cable may be defective.

5. Go to the control connector on the motor.

6. Insert the black meter lead into the connector shell hole containing the single green wire.

7. Insert the red meter lead into the connector shell hole containing the White wire. The DC voltage should be ~22Vdc. If it is not, the control cable is defective. If the voltage is greater than 10Vdc and the motor does not run, contact the equipment manufacturer for further instructions.

8. If the EVO/ECM series control includes an off feature, turn the control to off. The motor should stop and the voltage between the green and black wires should fall to less than 0.2Vdc.

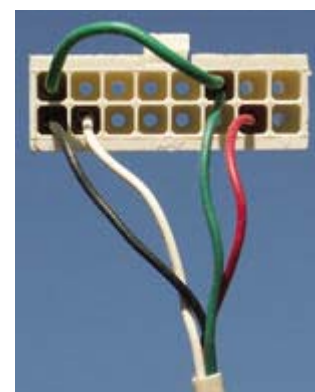
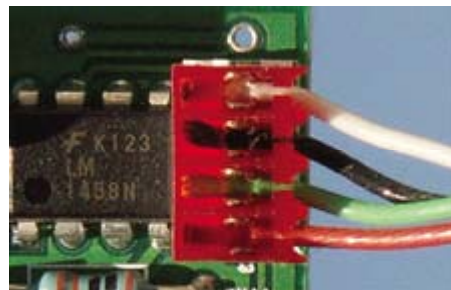

**Automation Off Test**

*If an automation system turns the ECM motor on/Off by directly feeding 24Vac to the EVO/ECM series controller, perform the Off Test.*

Turn the ECM motor off using the Automation System.

1. Touch the black lead to the common (Green) wire on the 4 pin motor connector.

2. Touch the red lead to the Tachometer (Black) wire on the 4 pin motor connector.

3. The Dc voltage should be less than 3Vdc

4. If the voltage is too high, the Automation Control is leaking current through its On/Off switching device.

## Troubleshooting EST Controllers (PWM) - continued

EVO/ECM Series

Control Test Procedure

Variable Speed Test    *The motor should be running to perform this test.*

Set the multimeter to read 24Vdc.

1. Touch the black lead to the common (Green) wire on the 4 pin motor connector.
2. Touch the red lead to the Speed (Red) wire on the 4 pin motor connector.
3. Set the EVO/ECM series controller to full speed.
4. The Dc voltage should be equal to the voltage on the white wire (~22Vdc). The motor should run at full speed.
5. If the motor does not run at full speed, the cable may be defective.
6. Go to the control connector on the motor.
7. Insert the black meter lead into the connector shell hole containing the single green wire.
8. Insert the red meter lead into the connector shell hole containing the Red wire. The DC voltage should equal to the voltage on the white wire (~22Vdc). If it is not, the control cable is defective. If the voltage is ~22Vdc and the motor does not run at full speed, contact the equipment manufacturer for further instructions.

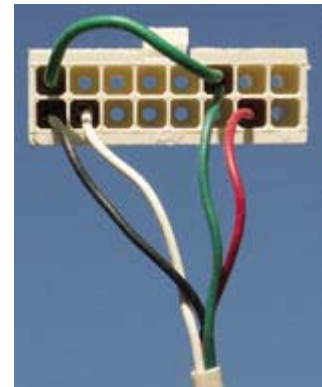
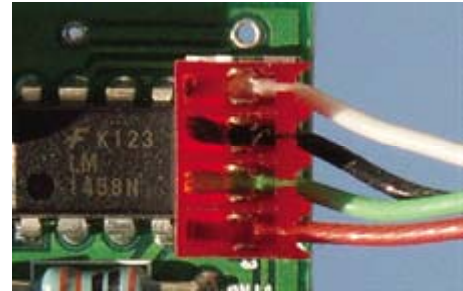

## Troubleshooting EST Controllers (PWM) - continued

EVO/ECM Series

Control Test Procedure

---

**Tachometer Test** *This test only applies to EVO/ECM series controls that display or transmit RPM information. The motor should be connected but turned off or running at minimum speed for this test.*

Set the multimeter to read 5Vdc.

1. Touch the black lead to the common (Green) wire on the 4 pin motor connector.
2. Touch the red lead to the Tachometer (Black) wire on the 4 pin motor connector.
3. You should read about 5Vdc.
4. Go to the control connector on the motor.
5. Insert the black meter lead into the connector shell hole containing the single green wire.
6. Insert the red meter lead into the connector shell hole containing the Black wire. The DC voltage should about 5Vdc. If it is not, the control cable is defective. Swap the EVO/ECM series control with a known good control to determine if the problem is with the EVO/ECM series control. If the problem persists, contact the equipment manufacturer for further instructions.

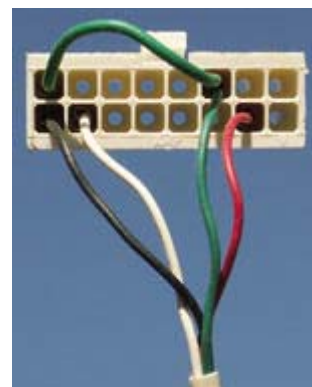
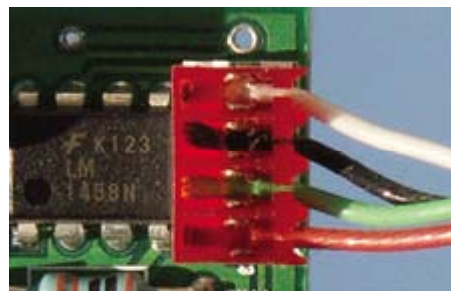



# Installation, Operation, & Maintenance

## Standard Replacement Parts List

Item	Part Number	Description
1	13-14	CSC-3011 Pneumatic Controller
2	13-34	MCP-3631 Pneumatic Actuator (5-10 PSI)
3	13-43	CSE-1102 Pressure Switch
4	13-44	PE Switch CCE-1003
5	15-87	Motor – 1/6HP 120V
6	15-88	Motor – 1/4HP 120V
7	15-89	Motor – 1/2HP 120V
8	15-90	Motor – 3/4HP 120V
9	15-91	Motor – 1HP 120V
10	15-82	Motor – 1/6HP 277V
11	15-83	Motor – 1/4HP 277V
12	15-84	Motor – 1/2HP 277V
13	15-85	Motor – 3/4HP 277V
14	15-86	Motor – 1HP 277V
15	13-31	CSP-5001 Analog Electronic Controller / Actuator
16	13-32	Thermostat – CTE-5101
17	13-35	Thermostat – CTE-5103
18	13-34	Thermostat – CTE-5104
19	13-26	Changeover Relay REE-1005
20	13-45	Temp Sensor STE-1002 (for REE-1005)
21	13-46	Trigger Relay REE-5002 (adjustable fan trip voltage)
22	13-36	Trigger Relay REE-5001
23	13-05	R8222D-1022 SPDT Fan Interlock Relay 120V coil
24	13-24	Transformer 277/24 40VA
25	13-19	Transformer 120/24 40VA
26	12-83	Velocity Wing 6"
27	12-84	Velocity Wing 7"
28	12-85	Velocity Wing 8"
29	12-86	Velocity Wing 9"
30	12-87	Velocity Wing 10"
31	12-88	Velocity Wing 12"
32	12-89	Velocity Wing 14
33	12-90	Velocity Wing 16"
34	13-47	Fuse Holder - 500V 30 AMP "Bussman" HPG/HP
35	15-65	MCSPALL-120 Motor Speed Controller 120V
36	15-37	MCSPALL-277 Motor Speed Controller 277V
37	15-26	Disconnect Switch - SPST
38	15-29	Replacement Filter – 18" x 18" x 1" (for QST-17 and QST-25)
39	15-23	Replacement Filter – 18" x 20" x 1" (for QST-50)
40	15-36	Replacement Filter – 20" x 24" x 1" (for QST-75 and QST-10)

**Note:** Anemostat reserves the right to make appropriate substitutions. Call Factory for any parts not shown above.