

Anemostat®

SUBMITTAL

A MESTEK COMPANY

1220 Watson Center Road • Carson, CA 90745-4206
 (310) 835-7500 • FAX (310) 835-0448
 airhelp@anemostat.com • www.anemostat.com

for
TechZone
Ceilings

Model **TAZR-50**
STRAIGHT LINE
ADJUSTABLE DIFFUSER
 15/16" TEGULAR
 1/2" SLOT WIDTH

DIFFUSERS

PRODUCT FEATURES

- Designed for use with Armstrong TechZone Ceiling Systems
- Standard lengths = 24", 30", 36", 48", 60", 72" (custom lengths available)
- 1/2" Slot Width, 1 or 2 slots (2 slot configuration shown)
- Includes plenum mounting yokes

CONSTRUCTION DETAILS

- Extruded aluminum, adjustable linear slot diffuser

Finish:

- Arctic White Border and Center Tees, Black Volume / Pattern Controllers
- Optional Anemostat Color
- Custom Color Match

MODELS

Supply Diffusers

- TAZR-S-T** 15/16" Tegular Ceiling Returns (No Volume / Pattern Controllers)
- TAZR-R-T** 15/16" Tegular Ceiling

# OF SLOTS	C	D
1	2-1/4	1-9/16
2	1-5/8	2-13/16

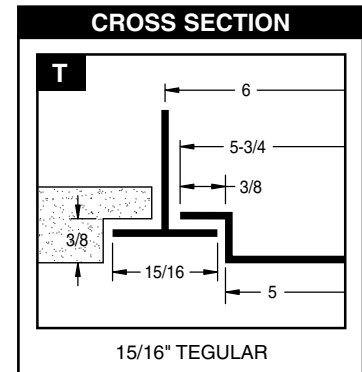
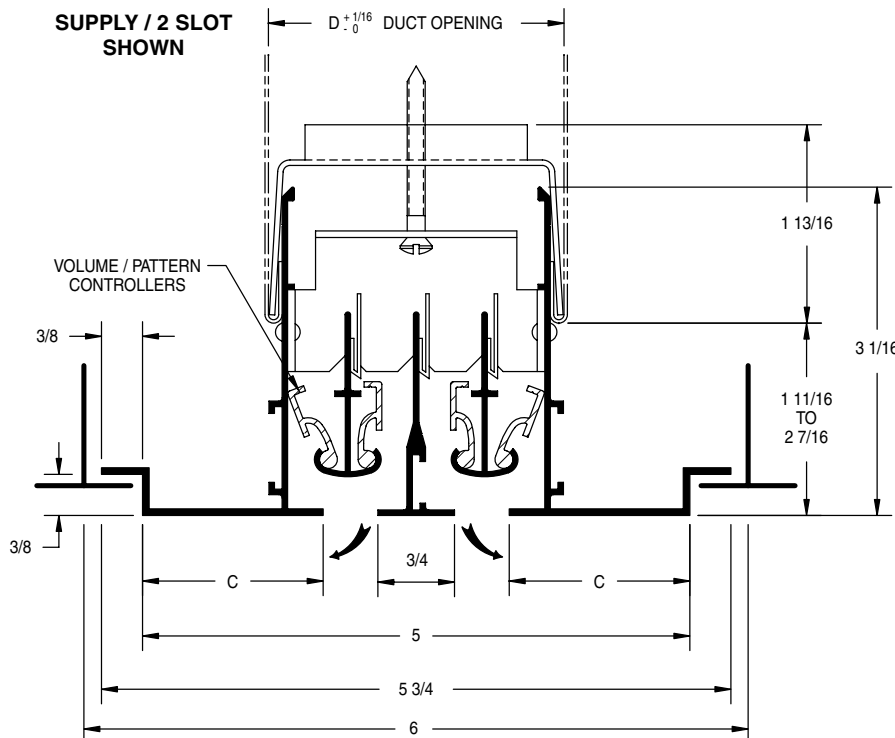
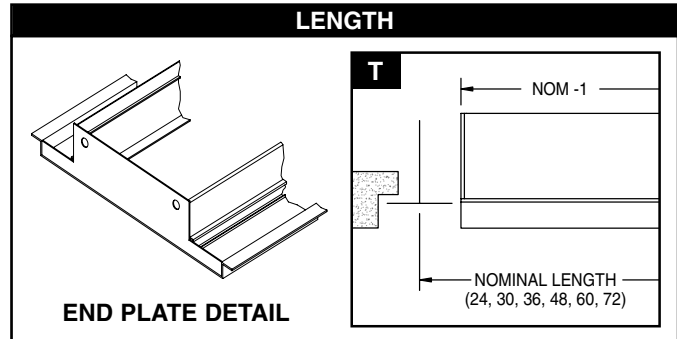

Armstrong and TechZone are registered trademarks of Armstrong World Industries, Inc.

All dimensions are in inches.

JOB NAME:

SUBMITTED BY: