

Anemostat®

SUBMITTAL

A MESTEK COMPANY

1220 Watson Center Road • Carson, CA 90745-4206
 (310) 835-7500 • FAX (310) 835-0448
 airhelp@anemostat.com • www.anemostat.com

BATTENS

SLIP-ON BATTENS

DIFFUSERS

PRODUCT FEATURES

- Slip-on battens are field cut to final, installed length. Factory provides long lengths for this purpose.

MATERIAL AND FINISH

- Steel with White Baked Epoxy
- Aluminum with White Baked Epoxy
- 304 Stainless Steel, #4 Polish
- 304 Stainless Steel with White Baked Epoxy

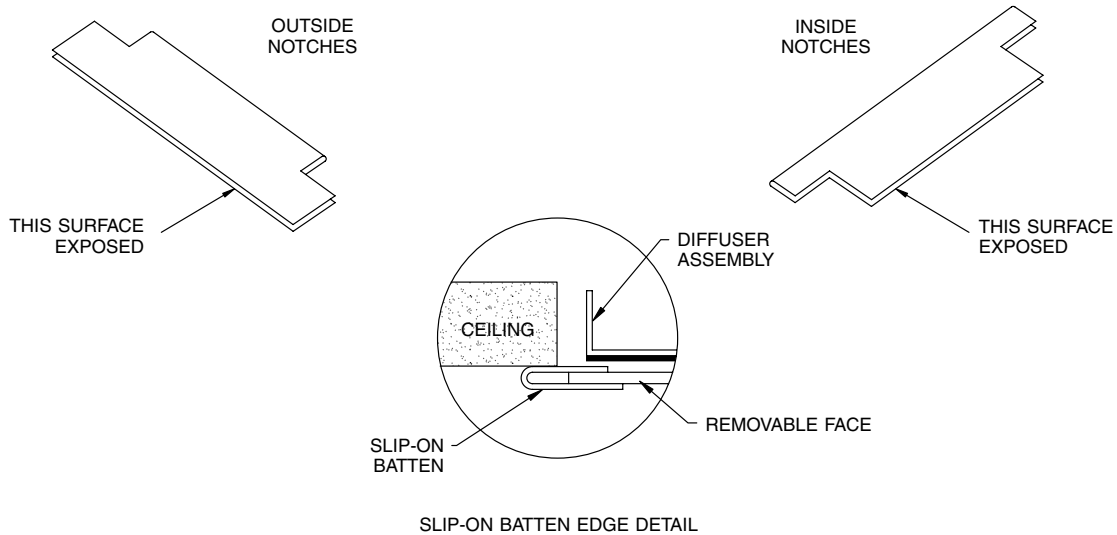

TYPICAL ARRANGEMENT REQUIRING SLIP-ON BATTENS

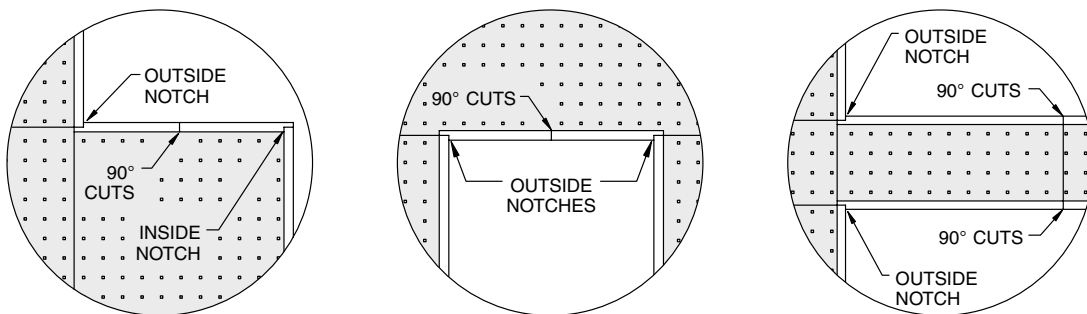

All dimensions are in inches.

JOB NAME:

SUBMITTED BY: