



TECHNICAL DATA
FROM
Anemostat[®]
DOOR PRODUCTS
A MESTEK COMPANY

P.O. BOX 4938 • 1220 WATSONCENTER ROAD
CARSON, CA 90745-4206
(310) 835-7500 • FAX (310) 835-0448

e-mail: sales@anemostat.com • website: www.anemostat.com

StormPro-HR™

LO-PROFILE HURRICANE RATED
METAL VISION FRAME ASSEMBLY

HURRICANE RATED



UNDERWRITERS'
LABORATORIES
FILE #R26087



Florida Building Code
Hurricane Approval

NOT FIRE RATED

DETAIL DRAWING

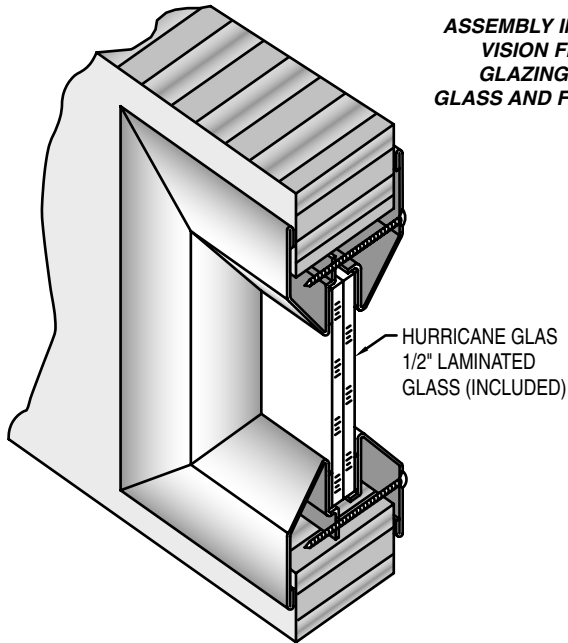

ASSEMBLY INCLUDES:
VISION FRAME,
GLAZING TAPE,
GLASS AND FASTENERS

HURRICANE GLAS
1/2" LAMINATED
GLASS (INCLUDED)

Anemostat manufacturing dimensions ±1/32
Actual dimensions are nominal and may vary
based on component manufacturers tolerances.

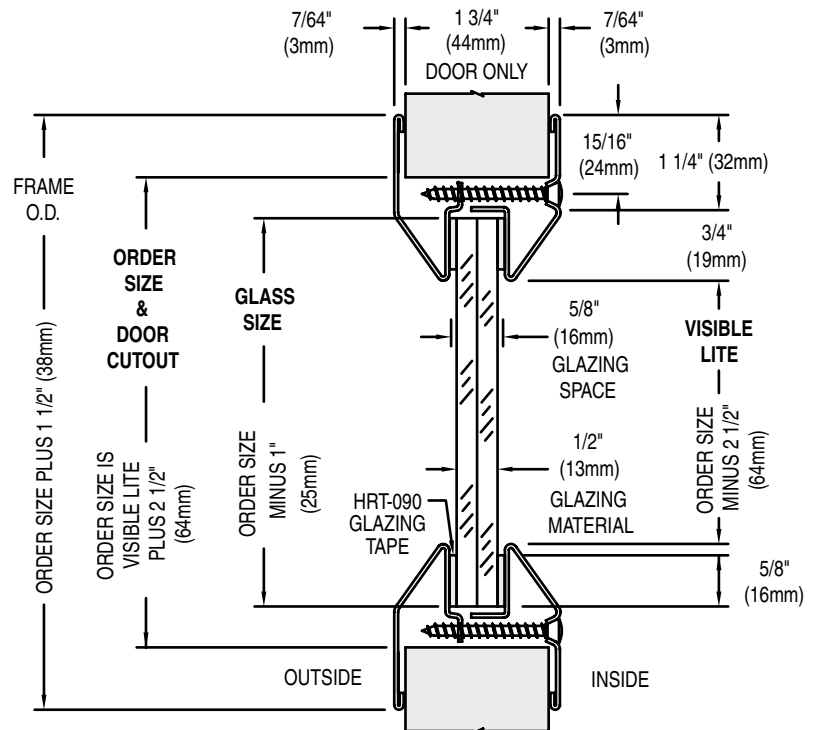

STANDARD PRODUCT FEATURES

- **MATERIAL:** 18 GA. Galvanized Steel, 1/2" clear glass and VHB glazing tape.
- **FINISH:** Grey Primer, Beige, or Bronze Baked Enamel.
- **INSTALLATION:** The StormPro™-HR is easy to install and provides a low profile, flush to the door look. Uses 1-3/4" sheet metal screws that pass through the door cutout, and fastens to the opposite side of the vision frame. 5/8 x .090 thick conformable 3M VHB glazing tape is supplied and installed on both sides of the glass.
- **DOOR THICKNESS:** For 1-3/4" Hurricane Approved Metal doors
- **GLAZING:** Glass is comprised of 2 pieces of 3/16" clear annealed with a .120 Uvekol™ "S" clear laminate. Overall glass thickness is 1/2".
- **AESTHETICS:** Tight mitered corners, beveled glass stop and low profile, provide a clear tapered look.
- **MAXIMUM SIZE:** 36" wide x 72" tall cutout (visible lite 33-1/2" x 69-1/2")
- **NOTE:** For exterior use, high humidity or salt air application, product must be galvanized or stainless steel.

OPTIONAL FEATURES

- **MATERIAL:** #304 Stainless Steel, #4 Finish(Satin), Hot Dipped, or Zinc Plated.
- **FINISH:** Special Order Baked Enamel Colors (as per sample chip supplied). Plated Finishes to match the lock, hinges and closer.
- **FASTENERS:** Special Security Screw Fasteners, See Page 17, this section.

FIRE RATINGS

- StormPro-HR™ is not fire rated

HURRICANE TEST / WINDSTORM APPROVALS (w/ U.L. marking)

- Successfully tested in accordance with ASTM E1886, E1996 and E330 and ANSI 250.13-Impact 350 FT LBS. Design Pressure: +/- 70 PSF (large missile test).
- Complies with Florida Building Code Standards
- **IMPORTANT:** Interpretation of building and fire codes may vary. Consult with the local authority having jurisdiction in your area, to determine appropriate Standards.
- **ATTENTION:** Must be used in an appropriately tested and hurricane rated door assembly.

Job Name & Location	Submitted by