



TECHNICAL DATA
FROM
Anemostat[®]
DOOR PRODUCTS
A MESTEK COMPANY

P.O. BOX 4938 • 1220 WATSONCENTER ROAD
CARSON, CA 90745-4206
(310) 835-7500 • FAX (310) 835-0448

e-mail: sales@anemostat.com • website: www.anemostat.com

FGS-75

METAL
VISION FRAME



UNDERWRITERS'
LABORATORIES

FIRE
RATINGS



WARNOCK
HERSEY

DETAIL DRAWING

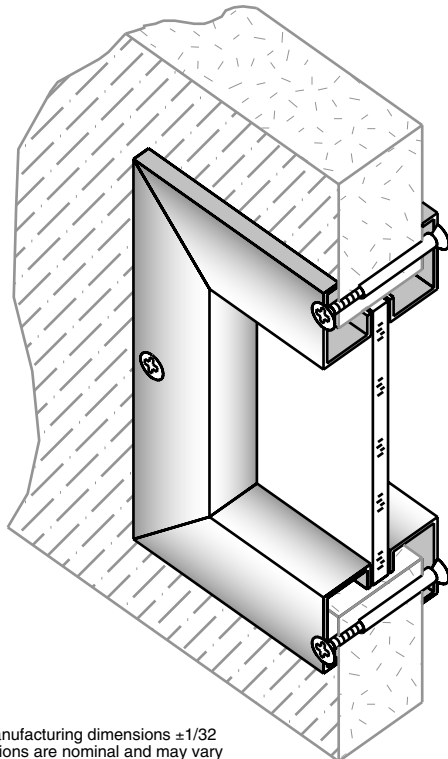

Anemostat manufacturing dimensions ±1/32
Actual dimensions are nominal and may vary
based on component manufacturers tolerances.

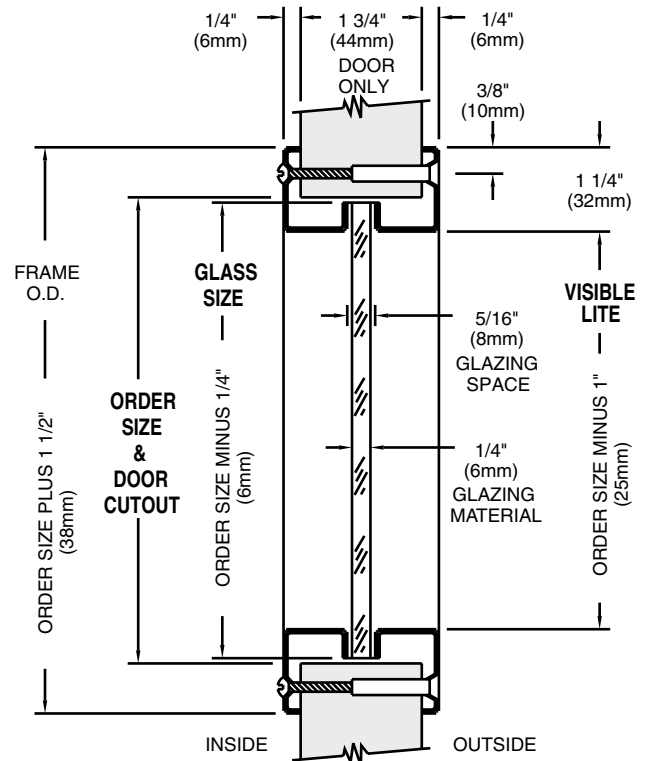

STANDARD PRODUCT FEATURES

- **MATERIAL:** 18 GA. Cold Rolled Steel.
- **FINISH:** Grey Primer, Beige or Bronze Baked Enamel.
- **INSTALLATION:** By drilling 1/4" holes thru the door, around the perimeter of the door cutout.
Frame has countersunk mounting holes for #8x32 phillips head steel thru bolts with a blank head on one side for flush appearance and added security.
- **DOOR THICKNESS:** For 1 3/4" Wood or Metal Doors.
- **GLAZING:** Should be 1/4" or 3/16" fire and/or safety rated with U.L. and/or W.H.I. classification markings.
Glazing space of 5/16" allows for glazing tape to be used on both sides of the glass.
- **AESTHETICS:** Tight mitered corners, 90° angle on glass stop for maximum visible lite area.
- **IMPORTANT:** Interpretation of building and fire codes may vary.
Consult with the local authority having jurisdiction in your area, to determine appropriate standards.
- **NOTE:** For Exterior use, High Humidity or Salt Air application, product must be Galvanized or Stainless Steel.

OPTIONAL FEATURES

- **MATERIAL:** #304 or #316 Stainless Steel, #4 Finish(Satin), Galvanized (Coil, Hot Dipped, or Electro Plated), Aluminum Mill Finish (not fire rated)
- **FINISH:** Custom Baked Enamel Colors (as per sample chip supplied).
Plated Finishes to match the lock, hinges and closer.
- **FASTENERS:** Special Security Screw Fasteners, See Page 31, this section.
- **SPECIALS:** Fractional Sizes, Lead Lined for X-ray applications, Glass or Door thickness (see FGS-IS or FGS-DBL).
- **HM CLIP:** Replaces the need for reinforcing channel in the door cutout, see page 32 this section.

FIRE RATINGS (w/ U.L. & W.H.I. classification markings) Positive Pressure

- **20 MINUTE:*** Approved listing at 3204 sq.in. visible lite (max. width 36", max. height 89").
 - **45/60 MINUTE:*** Approved listing at 2772 sq.in. visible lite (max. width 36", max. height 77").
 - **90 MINUTE:*** Approved listing at 1296 sq.in. visible lite (max. width 36", max. height 54").
 - **3 Hour:*** Approved listing at 100 sq.in. visible lite (max. width 12", max. height 33")
- * Must be used with FIRELITE NT and Fire listed glazing tape and be used in appropriately tested door assembly.
- **PLEASE NOTE:** On visible lite sizes larger than 1296 sq. in. on 20/45 min. and 100 sq. in. on 60/90/180 min., please consult with your Door / Frame Manufacturer's procedures, for their maximum glass size tested.

Job Name & Location	Submitted by

(3/08)

414A104A