



TECHNICAL DATA  
FROM  
**Anemostat**<sup>®</sup>  
DOOR PRODUCTS  
A MESTEK COMPANY

P.O. BOX 4938 • 1220 WATSONCENTER ROAD  
CARSON, CA 90745-4206  
(310) 835-7500 • FAX (310) 835-0448

e-mail: door@anemostat.com • website: www.anemostat.com

**Tempered IGU**  
1" (25mm) INSULATED

NOT FIRE RATED

CATEGORY II IMPACT/SAFETY RATED

DETAIL DRAWING

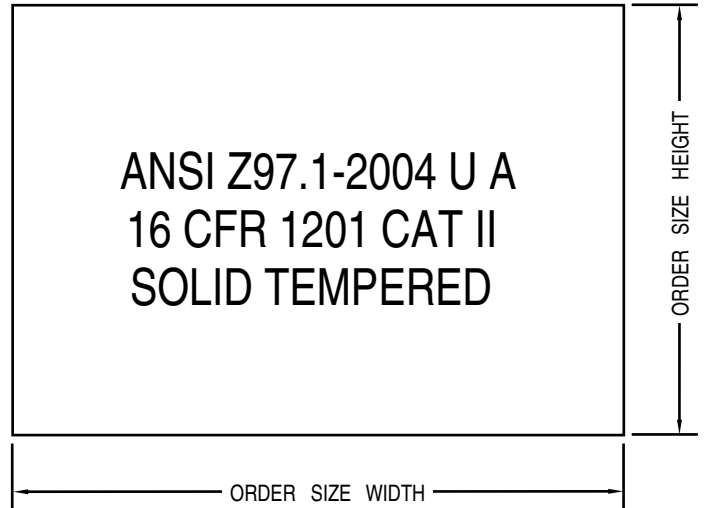
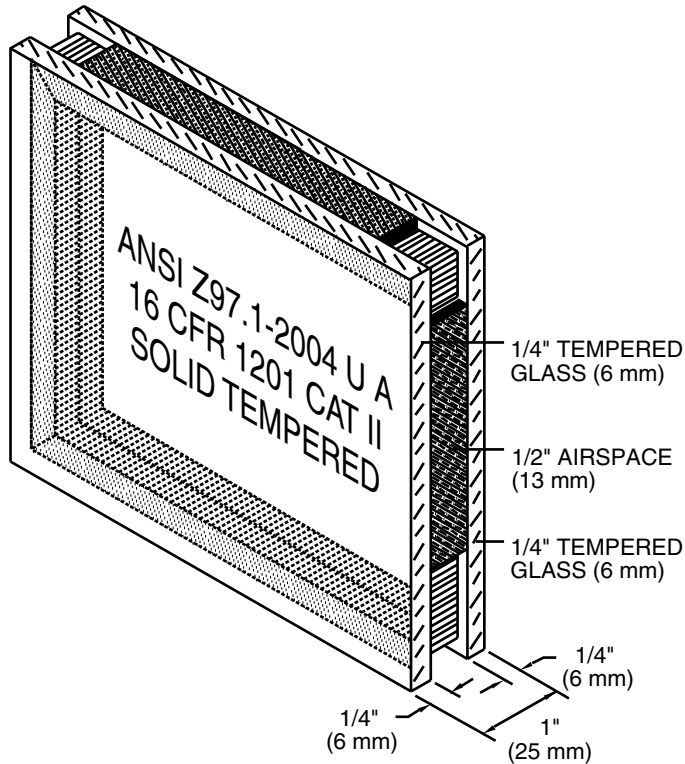

**STANDARD PRODUCT FEATURES**

- **MATERIAL:** 1/4" clear Tempered Glass is heat treated strengthened glass which is stronger than ordinary float glass.
- **STRENGTH:** It has bending and impact strengths which are 3 to 5 times higher than those of annealed glasses of the same thickness.
- **THERMAL SHOCK STRENGTH:** Is approximately three times as resistant to rapid temperature changes as annealed glass.
- **SAFETY:** Tempered Glass breaks into small particles upon impact, preventing serious injury, unlike annealed glass which can break into large, sharp pieces.
- **USES:** For applications where energy codes require an insulated unit and for interior applications for special needs such as sound reduction in non-fire rated doors and sidelites.

**OPTIONAL FEATURES**

- **COLORS:** Available in Bronze, Gray, Graylite, and Obscure.
- **SIZES:** Customized shapes to fit almost any shape vision frame. CANNOT be cut after manufacturing.

**IMPACT / SAFETY RATINGS**

- Meets ANSI Z97.1-2004 U A and CPSC 16 CFR 1201 Category II, Impact Test Standard.

Job Name & Location	Submitted by

(5/09)